

Raised Metal Planter

Parts List

- 4 x legs (A)- all legs are the same
- 2 x long frames (B)
- 1 x bottom plate (C)
- 2 x short frames (D)
- 26 x screws & 26 blind nuts (E)
- 4x plastic feet (F)

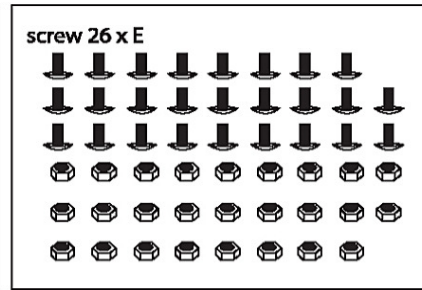
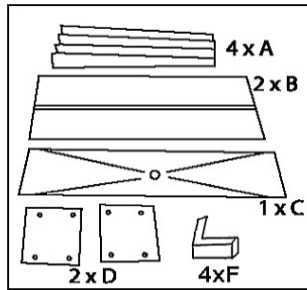

Correct Use:

This product is intended for planting and is designed for household living areas including balconies, terraces and gardens. This product is designed for private use only.

Assembly and Parts Lists

STEP 1:

Align the first leg (A) and the first short side (D). Fix these together with the supplied screws (E) and blind nuts.

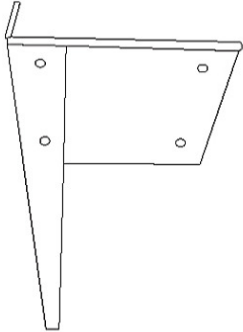

STEP 2:

Align the second leg (A) with the first short side (D). Fix these together with the supplied screws (E) and blind nuts.

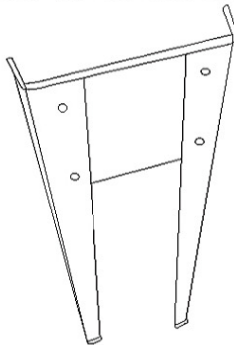

STEP 3:

Repeat Steps 1 & 2 with the second short side (D) and the 3rd and 4th legs (A). Place the plastic feet (F) for each legs.

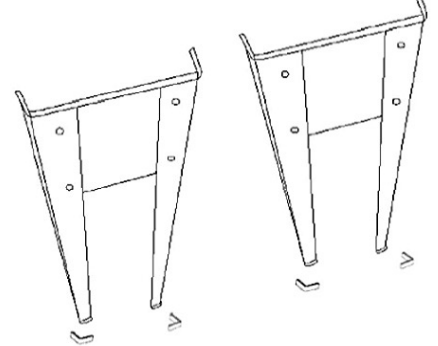

STEP 4:

On a flat, stable surface, align the holes of the long side of the long frame (B) with the leg holes (A). Fix these together with the supplied screws (E) and blind nuts.

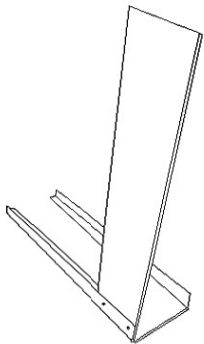

STEP 5:

Align the other long frame (B) with the other leg holes (A). Fix these together with the supplied screws (E) and blind nuts.

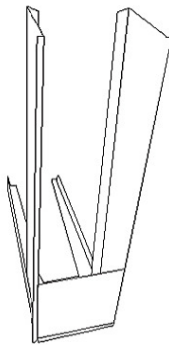

STEP 6:

Align the ready assembled short side (D) with the two long sides (B). Fix these together with the supplied screws (E) and blind nuts.

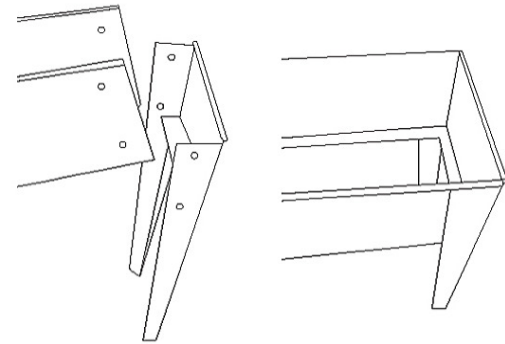

STEP 7:

From above the ready assembled base, attach the bottom plate (C). Fix these together with the supplied screws (E) and blind nuts.

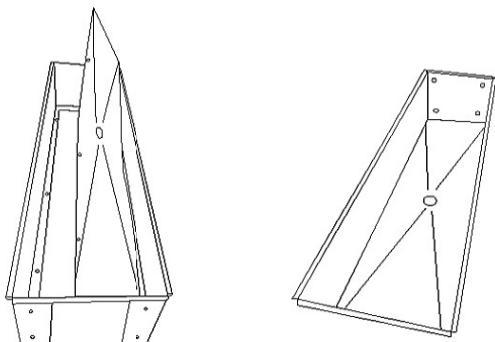

FINISHED PRODUCT:

