

## Assembly Instructions

# Palermo™ - Gazebo 3500

Approx. Dim.  
350.5 L x 350.5 W x 290 H cm / 138" L x 138" W x 114.2" H

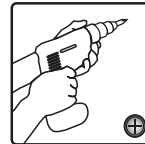
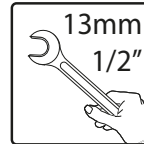
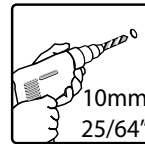
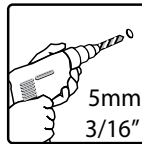
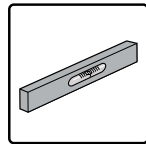
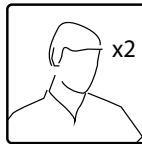

### After Sale Service

Email: [customer.service@palram.com](mailto:customer.service@palram.com)

USA 877-627-8476  
Canada 1 800-866-5749

England 01302-380775  
Germany 0180-522-8778

France 0169-791-094  
International +972 4-848-6942

[www.palramapplications.com](http://www.palramapplications.com)

**IMPORTANT**

Please read these instructions carefully before you start to assemble this product.  
Please carry out the steps in the order set out in these instructions.  
Keep these instructions in a safe place for future reference.

## » Care and Safety Advice

- Please follow the instructions as listed in this manual.
- Sort the parts and check against the contents list.
- For safety purposes we strongly recommend the product to be assembled by at least two people.
- Some parts have metal edges. Please be careful when handling components. Always wear gloves, shoes and safety goggles during assembly.
- Do not attempt to assemble the Gazebo in windy or wet conditions.
- Dispose of all plastic bags safely – keep them away from children's reach.
- Keep children away from the assembly area.
- Do not attempt to assemble the Gazebo if you are tired, have taken drugs, medications or alcohol, or if you are prone to dizzy spells.
- When using a stepladder or power tools, make sure that you are following the manufacturer's safety advice.
- Do not climb or stand on the roof.
- Heavy articles should not be leaned against the poles.
- Keep roof and gutters clear of snow, dirt & leaves.
- Heavy snow load on roof can damage the Gazebo making it unsafe to stand below or nearby.
- This product was designed and produced to be used as a Gazebo only.

If color was scratched during assembly it can be fixed with the following tints:  
Grey – RAL 7012

## » Cleaning instructions

In order to clean the Gazebo, use a mild detergent solution and rinse with cold clean water.

Do not use acetone, abrasive cleaners, or other special detergents to clean the panels.

## » Tools &amp; Equipment

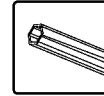

T001 (Supplied)

## » During Assembly

During assembly use a soft surface below the parts to avoid scratches and damages.



When encountering the information icon, please refer to the relevant assembly step for additional comments and assistance.

**Steps 6-11:**

- It is recommended to use a carton or other soft material under the lowered corner in order to avoid scratches and peeling of paint.

**Step 10:** Optional -if you wish to add curtains - Please thread the plastic clips through the rail in each profile in order to hang additional curtains (not supplied). Add clips according to the specific quantity of curtain rings.

**Steps 11+13:** Please note that threading of the screws should be done from the outside.

**Steps 12+14:** Please note that threading of the screws should be made from the bottom up. Afterwards please use a screwdriver for easy screwing.

**Step 15b:** Please add silicone on the inner area of part **#7661** as illustrated.

**Step 21a:** Please drill holes in the panels to be located precisely parallel to the holes in profiles **#7744 + #7743**.

**Step 22:** Please level the profiles' legs and adapt screws and plugs to your specific ground type.

**Please note:** Screws and plugs are not supplied.

- Please tighten all screws at the end of assembly.

Pavement Stone

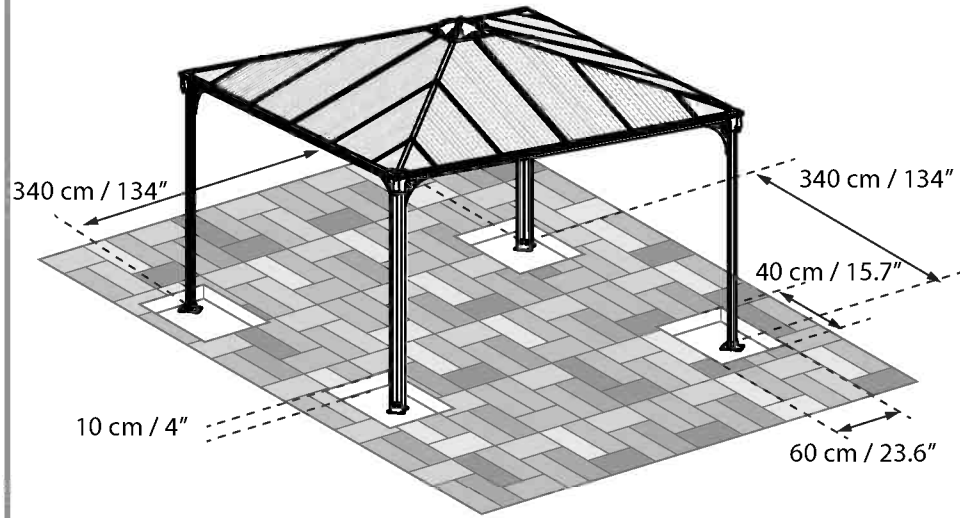

Asphalt / Soil

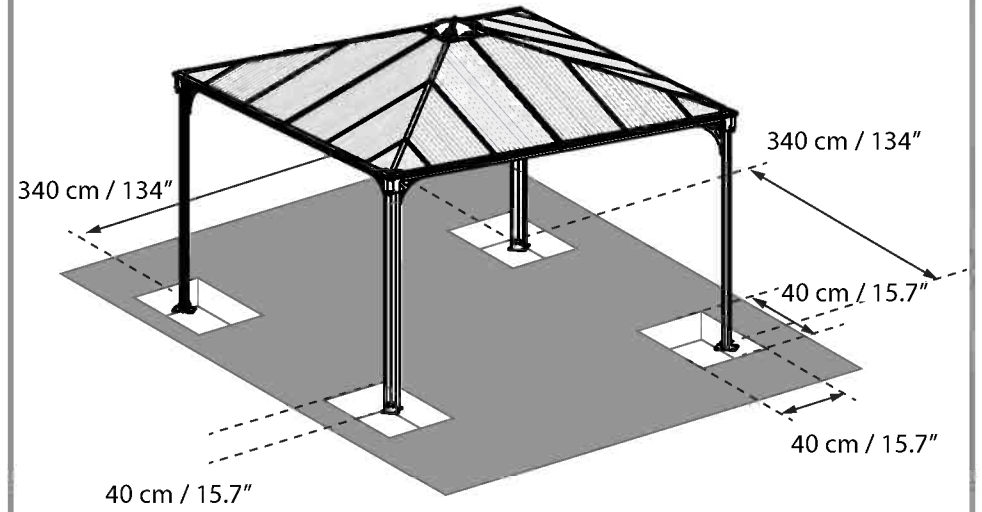

OR

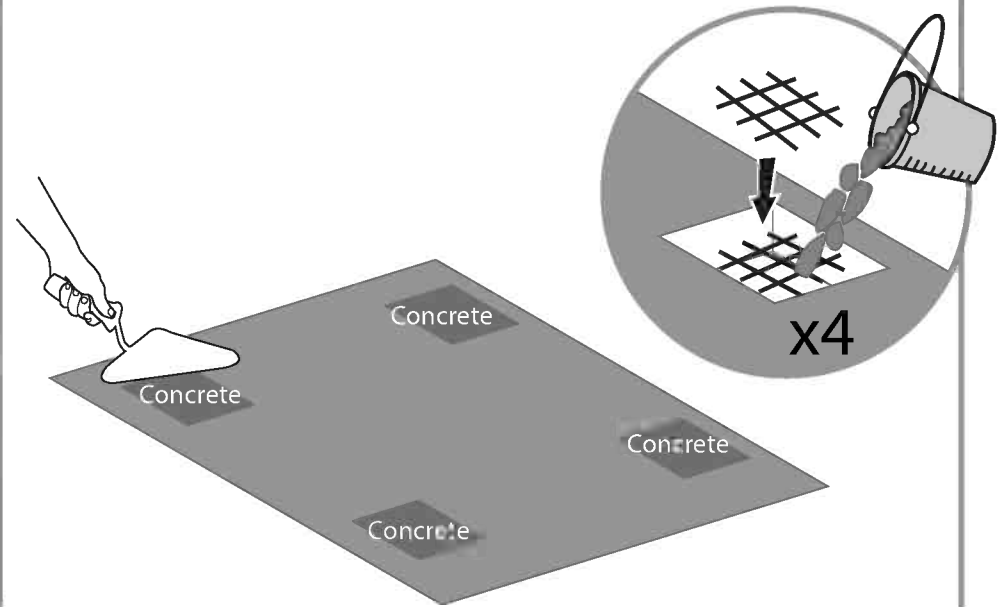
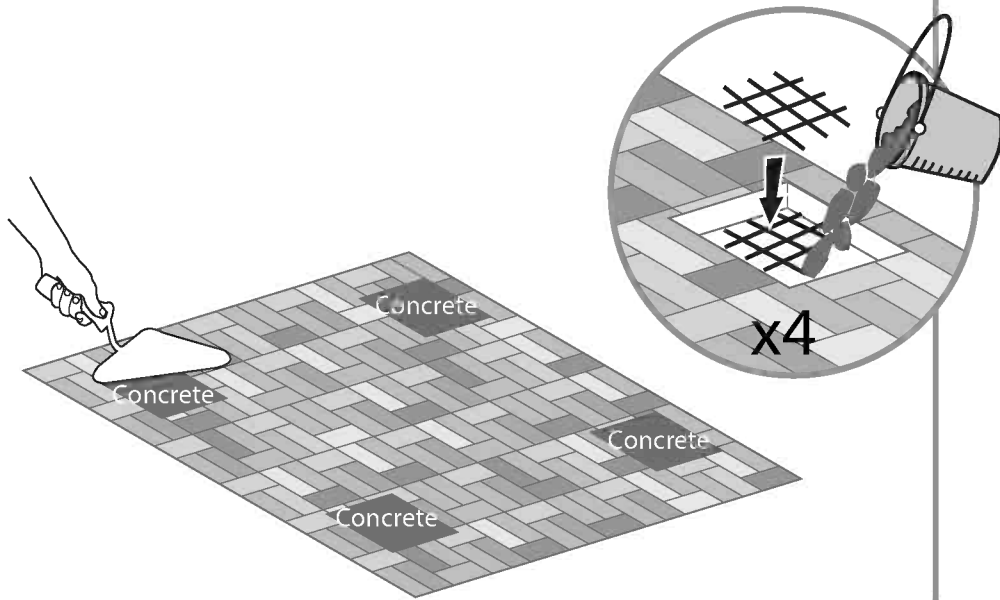

**IMPORTANT**

Lire attentivement ces instructions avant de commencer l'assemblage de cette tonnelle. Merci de suivre les étapes en respectant l'ordre mentionné sur cette notice. Conserver cette notice dans un endroit sûr pour toute référence ultérieure.

## » Conseils d'entretien et de sécurité

- Suivez les instructions telles qu'elles sont mentionnées sur cette notice.
- Vérifiez que le paquet contient bien toutes les pièces.
- Pour des raisons de sécurité, il est fortement recommandé qu'au moins 2 personnes participent au montage.
- Certaines pièces peuvent être coupantes. Merci de manipuler les pièces avec précaution.
- Toujours porter des gants, des chaussures et des lunettes de protection durant tout l'assemblage.
- Ne pas essayer de monter cette tonnelle par temps venteux ou pluvieux.
- Assurez-vous d'avoir bien jeté tous les emballages en plastique - Les mettre hors de la portée des enfants.
- Eloignez les enfants du site de montage.
- N'essayez pas de monter la tonnelle si vous êtes fatigué, si vous avez pris des médicaments ayant un effet sur votre état d'éveil, des drogues si vous avez consommé de l'alcool, ou si vous êtes sujet aux vertiges.
- Assurez-vous de bien suivre les conseils de sécurité du fabricant lorsque vous utilisez une échelle ou des outils électriques.
- Ne pas grimper ni s'accrocher au toit.
- Les articles lourds ne doivent pas être posés sur les poteaux et la toiture.
- Veillez à ce que le toit et les gouttières soient toujours propres en retirant la neige, les feuilles mortes et la poussière.
- Le produit pourrait subir des dommages en cas de grosses chutes de neige sur le toit, il serait alors dangereux de vous tenir sous le toit ou à proximité.
- Ce produit a été conçu afin de servir de tonnelle à usage domestique uniquement.

**Attention:** Les chevilles fournies sont pour support béton. Adapter votre quincaillerie en fonction du support.

Si la peinture a été raillée pendant l'assemblage, elle peut être réparée en utilisant le Gris RAL 7012

## » Instructions de nettoyage

Pour nettoyer votre tonnelle, utilisez un détergent doux et rincez avec de l'eau propre et froide.

Ne pas utiliser d'acétone, de produits abrasifs ni tout autre détergent spécial pour nettoyer les panneaux.

## » Vous aurez besoin de

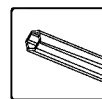

TOO1 (Fourni)

## » Pendant l'assemblage

Positionnez les pièces sur une surface souple pour éviter toute rayure ou dégât.



Lorsque vous rencontrez l'icône information, merci de vous référer à l'étape d'assemblage appropriée pour toute remarque et assistance additionnelle.

**Etape 6-11:** Afin d'éviter toute égratignure ou écaillage de la peinture, il est recommandé d'utiliser un carton ou un autre matériel souple sous l'angle inférieur.

**Etape 10:** En option, si vous souhaitez ajouter des rideaux –  
Enfilez s'il vous plaît les clips en plastiques à travers le rail dans chaque profil pour accrocher des rideaux (non fournis).  
Répéter les étapes en fonction de la quantité anneau de rideau.

**Etape 11+13:** Noter qu'il faut enfilez les vis doit être fait de l'extérieure.

**Etape 12+14:** Noter qu'il faut enfilez les vis de bas en haut. Ensuite utilisez un tournevis à cliquet pour faciliter le vissage.

**Etape 15b:** Ajoutez du silicone à l'intérieure de la pièce **#7661** comme illustré.

**Etape 21a:** Percez des trous dans les panneaux situé exactement parallèles aux trous qui se trouve dans les profils **#7744 + #7743**.

**Etape 22:** Nivellez les poteaux et adaptez les vis et chevilles au type de sol.

\* **Notez :** Les vis et chevilles fournies sont pour support béton uniquement. Adapter votre quincaillerie en fonction du support. les vis et chevilles ne sont pas fournis.

- Serrez toutes les vis lorsque l'assemblage est terminé.

Dalles et pavés béton

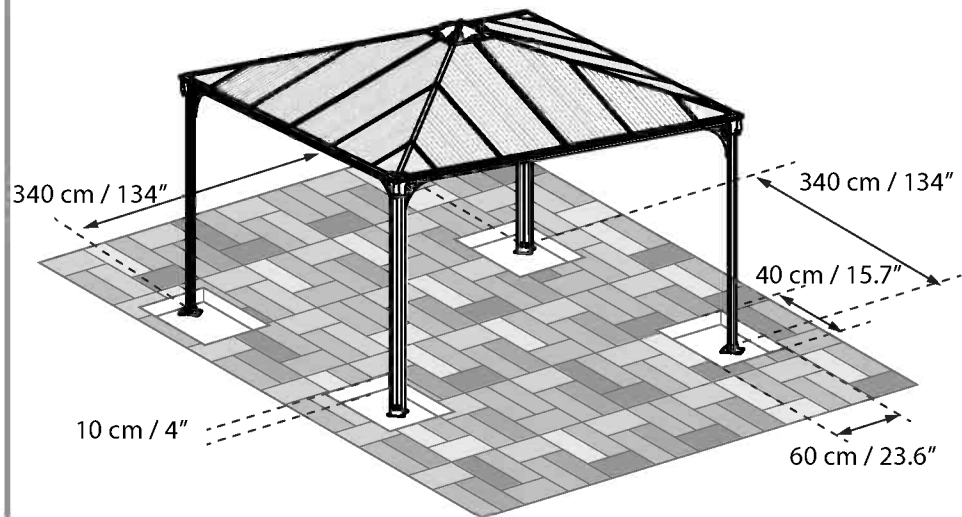

OU

Asphalte

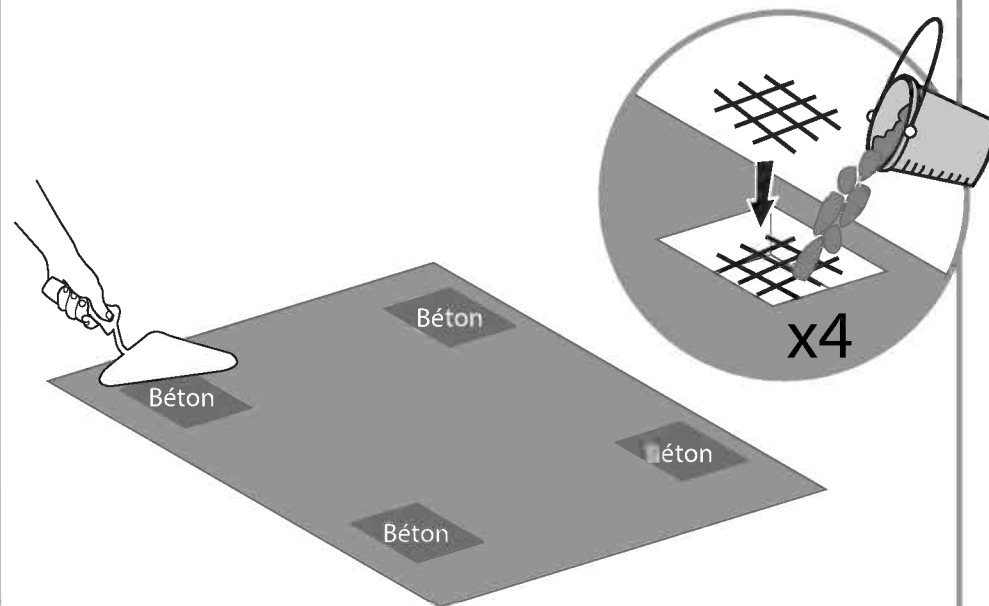
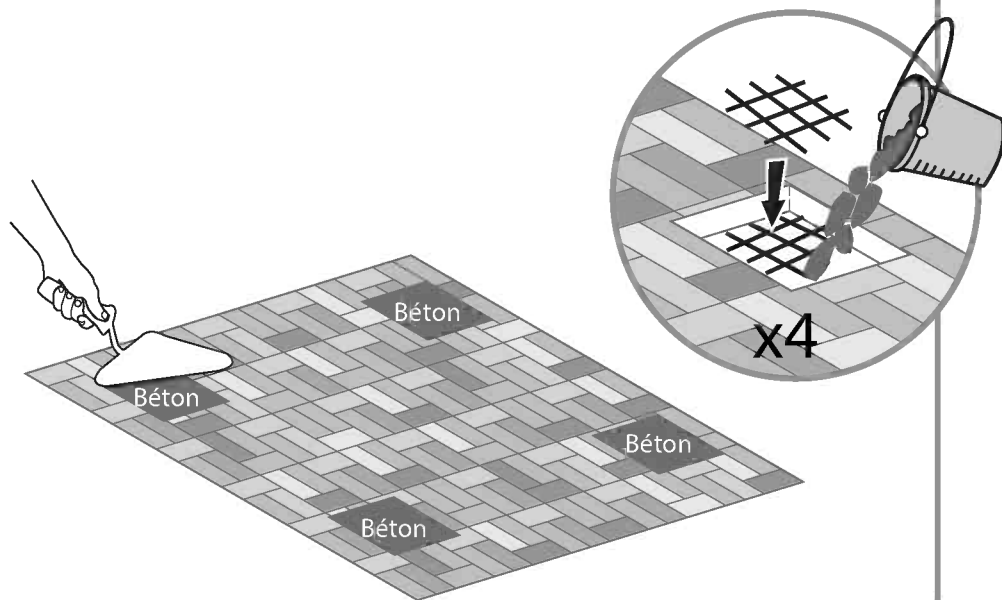
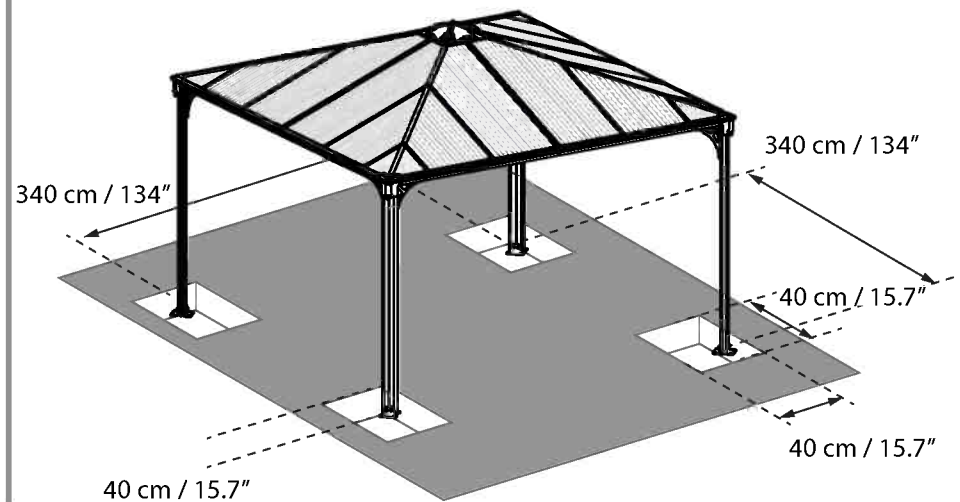

**WICHTIG**

Bitte lesen Sie diese Anweisungen sorgfältig durch, bevor Sie mit dem Aufbau des Gewächshauses beginnen. Führen Sie den Aufbau in der in den Gebrauchsanweisungen aufgeführten Reihenfolge Schritt per Schritt aus. Heben Sie diese Anweisungen an einem sicheren Ort auf, um später auf sie zurückgreifen zu können.

## » Pflege und Sicherheitshinweise

- Please follow the instructions as listed in this manual.
- Bitte folgen Sie die in diesem Handbuch aufgeführten Anweisungen.
- Sortieren Sie die Teile und überprüfen Sie die Inhaltsliste.
- Aus Sicherheitsgründen empfehlen wir dringend, dass das Produkt von mindestens zwei Menschen zusammengebaut wird.
- Einige Teile haben Metallkanten. Bitte seien Sie vorsichtig beim Umgang mit den Komponenten.
- Tragen Sie immer Handschuhe, Schuhe und Schutzbrille bei der Montage.
- Versuchen Sie nicht, das Produkt bei windigen oder nassen Bedingungen zu montieren.
- Entsorgen Sie alle Plastiktüten sicherheitsgemäß – bewahren Sie sie außerhalb der Reichweite von kleinen Kindern auf.
- Halten Sie Kinder vom Montagebereich fern.
- Versuchen Sie nicht ein Produkt zusammen zu bauen, wenn Sie müde sind, Drogen, Medikamente oder Alkohol genommen haben, oder wenn Sie zu Schwindelanfällen neigen.
- Bei Verwendung einer Stehleiter oder Elektrowerkzeugen, stellen Sie sicher, dass Sie die Sicherheitshinweise und Anweisungen des Herstellers befolgen.
- Steigen oder stehen Sie nicht auf dem Dach.
- Schwere Gegenstände dürfen nicht an den Pfosten angelehnt werden.
- Halten Sie Dach und Dachrinne frei von Schnee, Schmutz und Blättern.
- Extreme Mengen von Schnee auf dem Dach können das Gazebo schädigen und zu unsicheren Bedingungen in der Umgebung führen
- Dieses Produkt wurde entwickelt und hergestellt nur um seinen vorgesehenen Zweck zu dienen und darf nur dafür benutzt werden. If color was scratched during assembly.

Sollte die Farbe bei der Montage verkratzt werden, kann es mit den folgenden Farben nachlackiert werden: Grau - RAL 7012

## » Pflegeanleitung

Um das Produkt zu reinigen, verwenden Sie ein mildes Reinigungsmittel und reinigen Sie mit kaltem Wasser. Verwenden Sie kein Aceton, Scheuermittel oder andere spezielle Reinigungsmittel um das Paneel zu reinigen.

## » Sie werden brauchen

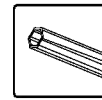

T001 (Sind inbegriffen)

## » Bei der Montage

Bei der Montage nehmen Sie eine weiche Plattform und stellen Sie diese unterhalb der Teile, um Kratzer und Beschädigungen zu vermeiden.



Beim Aufbau wird Ihnen das Informationssymbol begegnen. Für zusätzliche Kommentare und Unterstützung beziehen Sie sich bitte auf die entsprechende Aufbaustufe.

**Schritt 6-11:** Verteilen Sie den Silikon-Kleber vorsichtig entlang des kreuzförmigen Teils des Profils und drücken Sie die Profile danach sofort gegeneinander. Es wird empfohlen, den überschüssigen Silikon-Kleber zu entfernen.

**Schritte 10:** Optional – wenn Sie Vorhänge aufhängen möchten, dann fädeln Sie bitte bei jedem Profil die Plastikklammern auf die Schiene auf, um nachträglich Vorhänge daran befestigen zu können (nicht im Lieferumfang enthalten). Die notwendige Anzahl an Klammern richtet sich nach der Anzahl der verwendeten Vorhangringe.

**Schritte 11 +13:** Bitte beachten Sie, dass das Einschrauben der Schrauben von außen durchgeführt werden sollte.

**Schritte 12 +14:** Bitte beachten Sie, dass das Einschrauben der Schrauben von unten nach oben erfolgen sollte. Verwenden Sie bitte danach einen Schraubendreher um das Einschrauben zu erleichtern.

**Schritt 15b:** Bitte fügen Sie Silikon auf dem Innenbereich des Teils **#7661** hinzu, wie dargestellt.

**Schritt 21a:** Bitte bohren Sie die Löcher in den Platten genau parallel zu den Löchern in Profilen **#7744 + #7743**

**Schritt 22:** Bitte ebenen Sie die Beine der Profile und passen Sie die Schrauben und Dübeln an Ihren spezifischen Boden-Typ an.

\* **Bitte beachten Sie:** Schrauben und Dübel sind nicht im Lieferumfang enthalten. Bitte befestigen Sie alle Schrauben nach Abschluss der Montage.

Pflastersteine

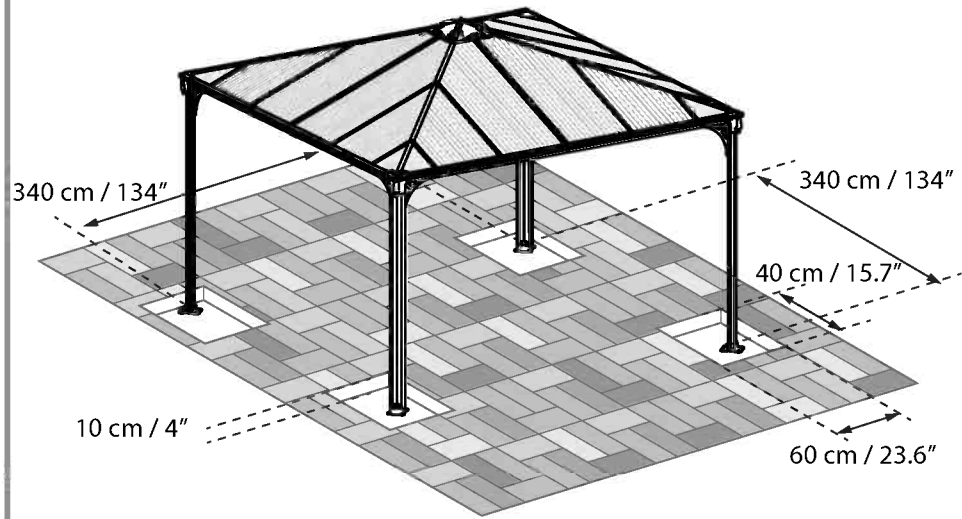



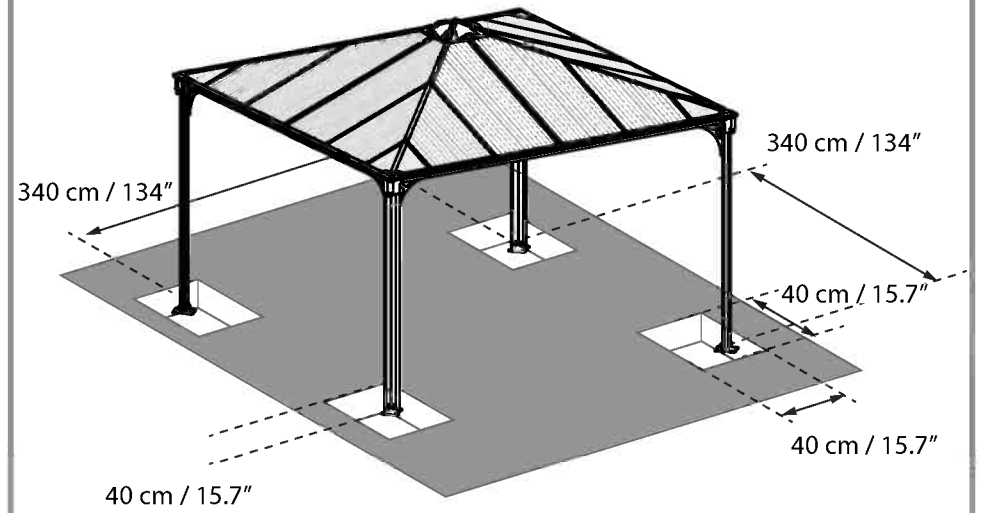

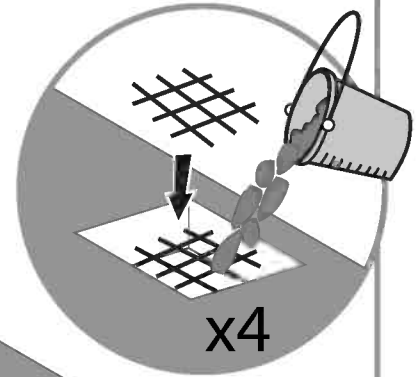
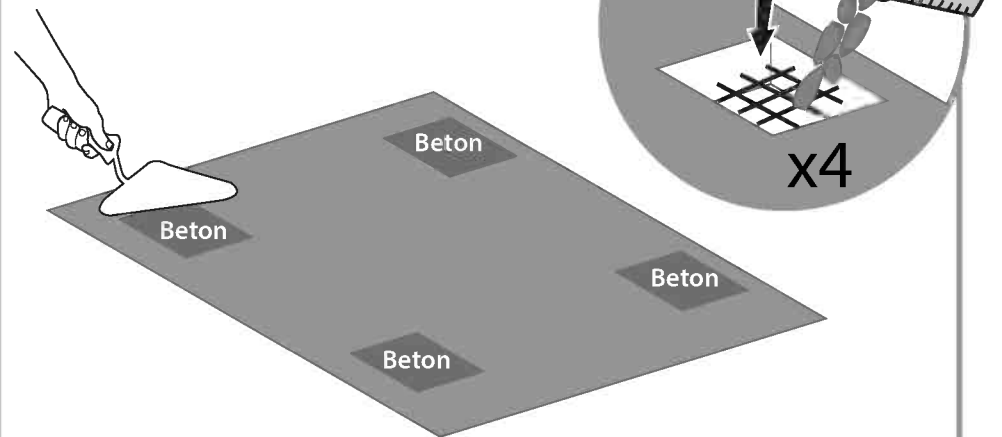
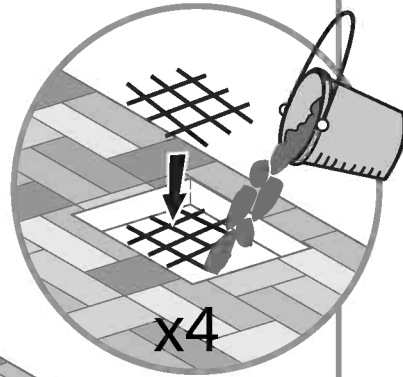
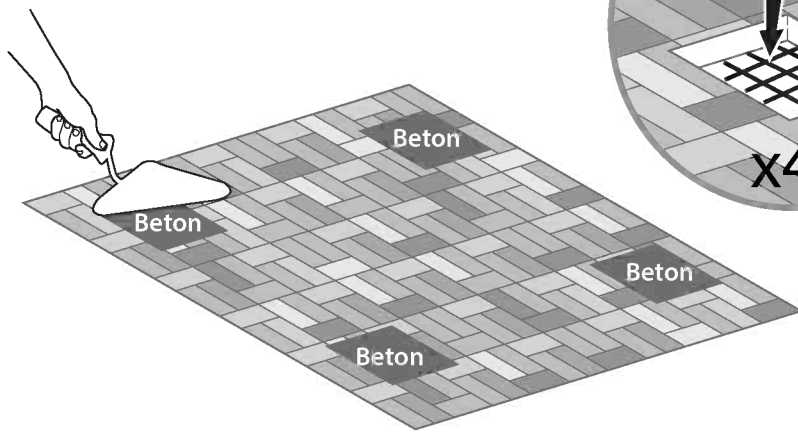

Asphalt/Erdreich

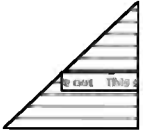
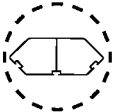
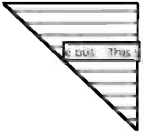

OR

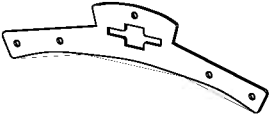

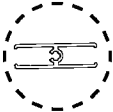
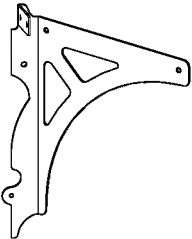
# Contents

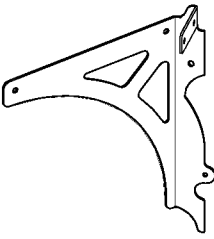
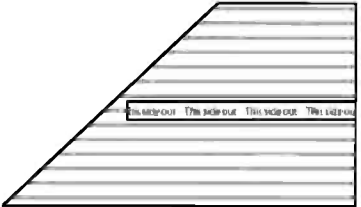
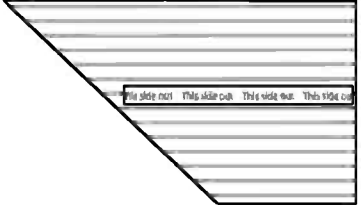
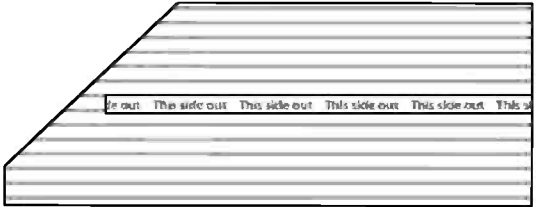
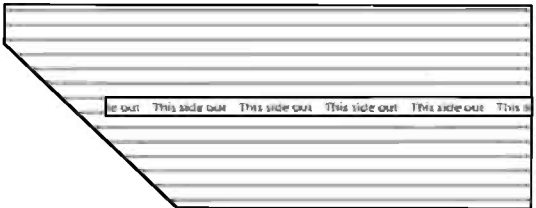
Item		Qty.	Item		Qty.
7810		4	7821		4
7664		4	7822		4
7812		4	7673		2
7811		4	7672		2
7866		8	7670		4
7865		8	7669		4
			7819		4
			7820		4
			7817		4
			7818		4



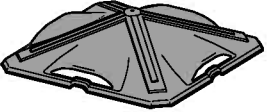
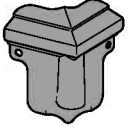

# Contents

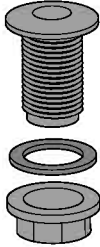

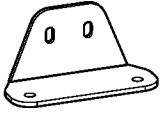
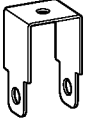
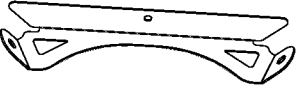
Item		Qty.
7662		1
7661		4

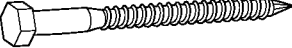
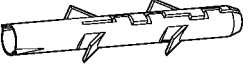
7681		4
------	---	---



212		8
7674		1
7671		4

Item		Qty.
4000		16 (+1)
4010		16 (+1)
5000		96 (+6)

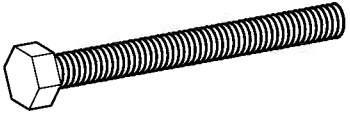

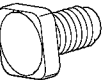

5001		16 (+2)
------	---	---------

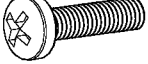
7680		17 (+1)
7119		16 (+1)
7679		8 (+1)
7567		8 (+1)

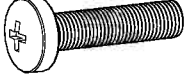
T001		1
------	--	---

Item		Qty.
411		16 (+2)
466		17 (+3)
421		40 (+3)

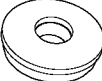
7682		1
------	---	---

433		10 (+1)
426		102 (+4)
4024		1
427		40 (+3)
7024		40 (+3)

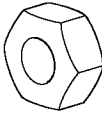
413		1
7121		49 (+3)

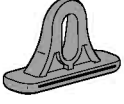



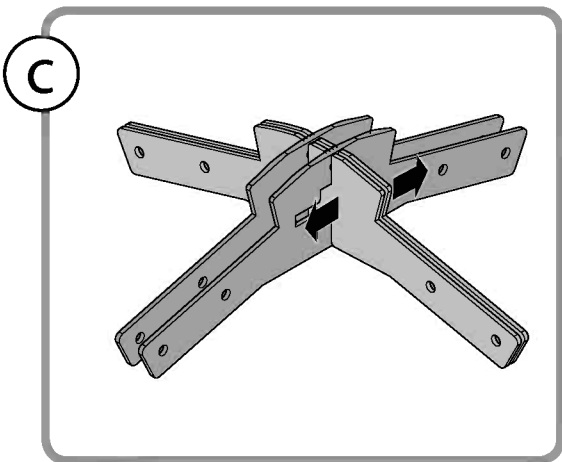
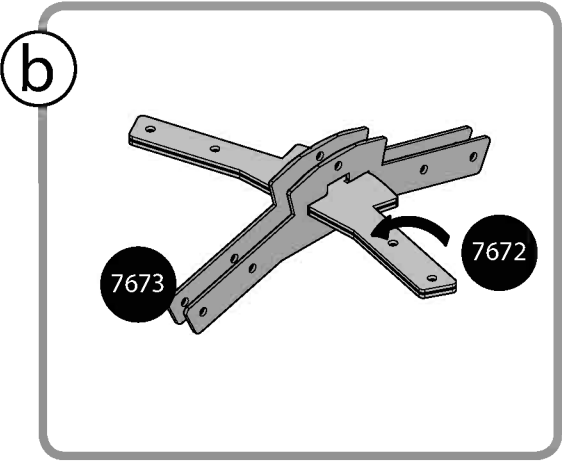
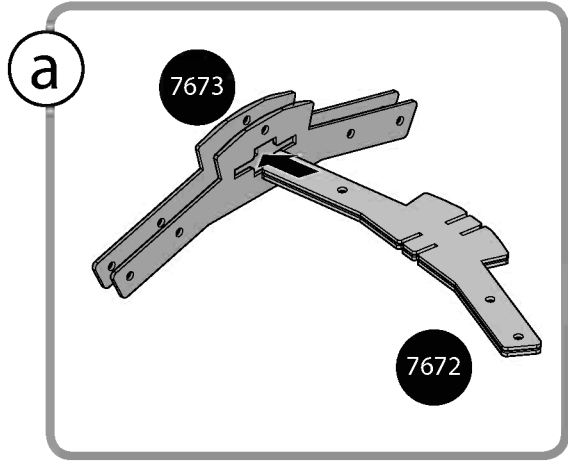
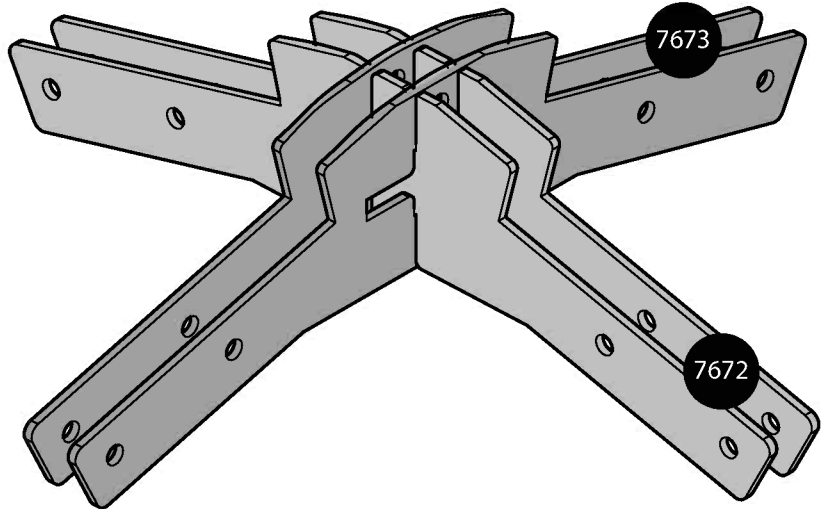
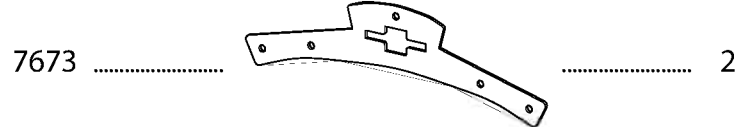

Item		Qty.
7829		70

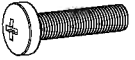

1

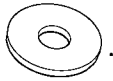
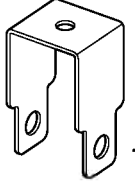

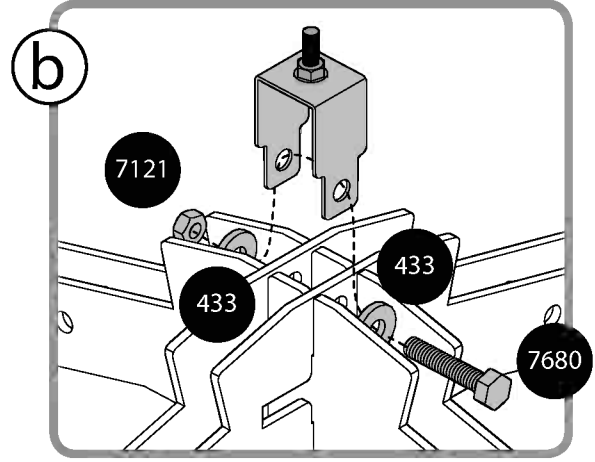
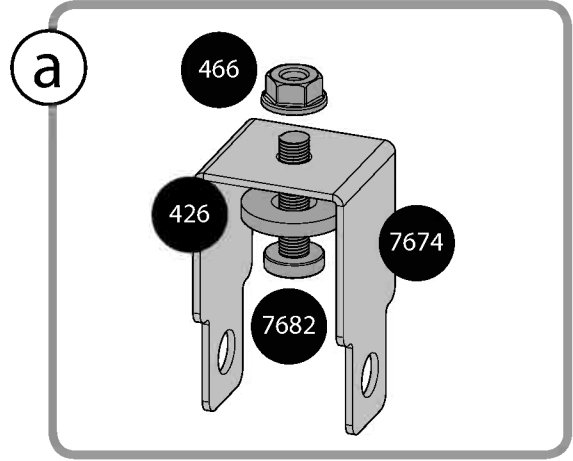
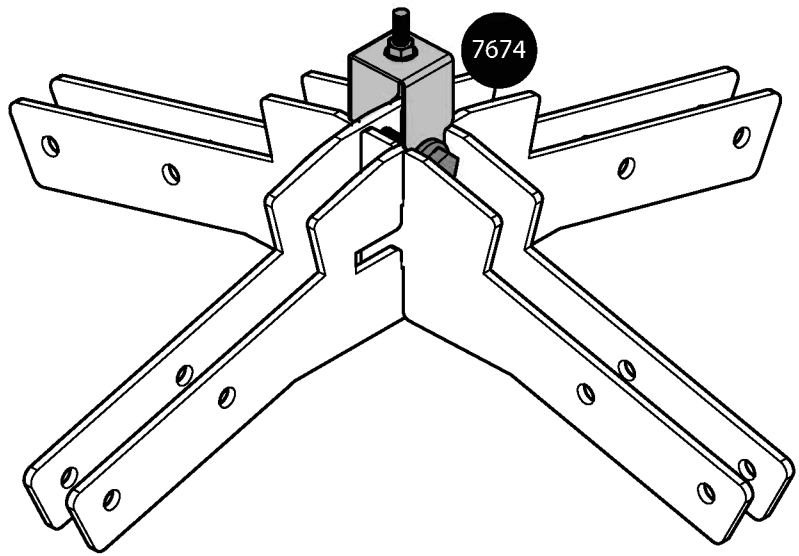
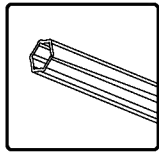

2

- |              |   |              |   |             |   |              |   |
|--------------|---|--------------|---|-------------|---|--------------|---|
| 7682 ..... 1 |  | 466 ..... 1  |  | 426 ..... 1 |  | 7674 ..... 1 |  |
| 7680 ..... 1 |  | 7121 ..... 1 |  | 433 ..... 2 |  |              |   |

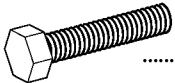

3

7811		4	7680		4	7121		4
						426		8

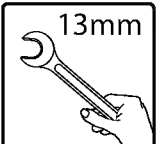
 13mm

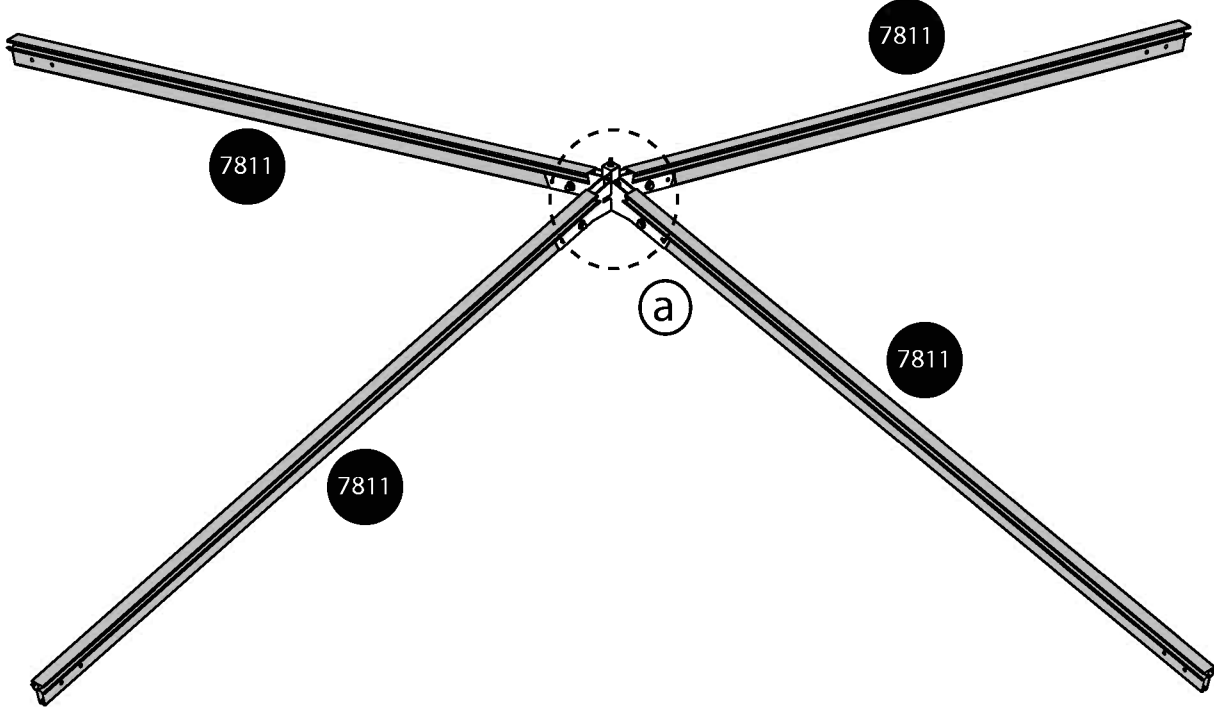

**a**

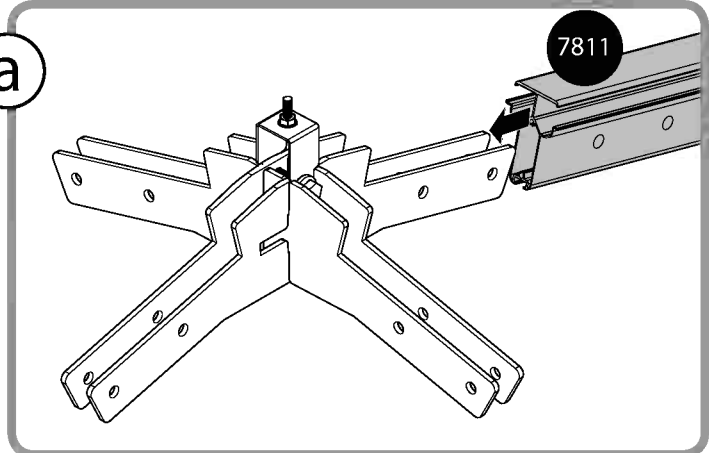

**b**

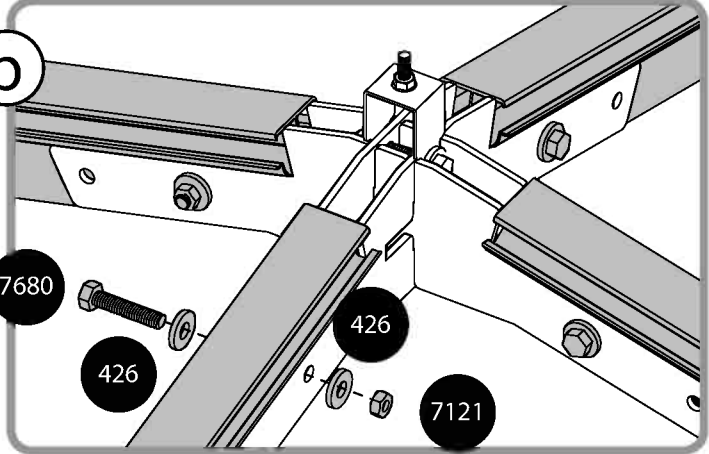

4

7680 ..... 4

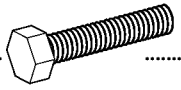

433 ..... 8



466 ..... 4



7121 ..... 4

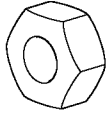

411 ..... 4

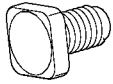

7671 ..... 4

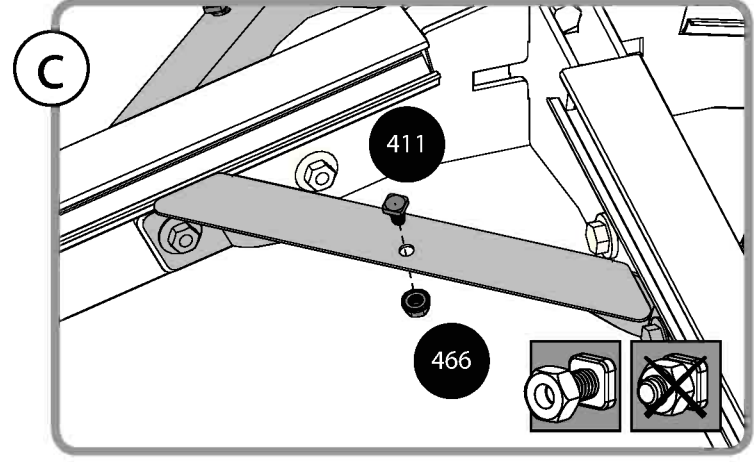
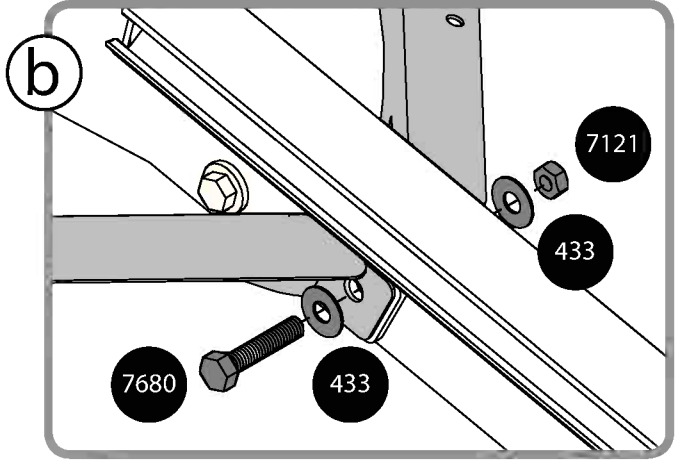
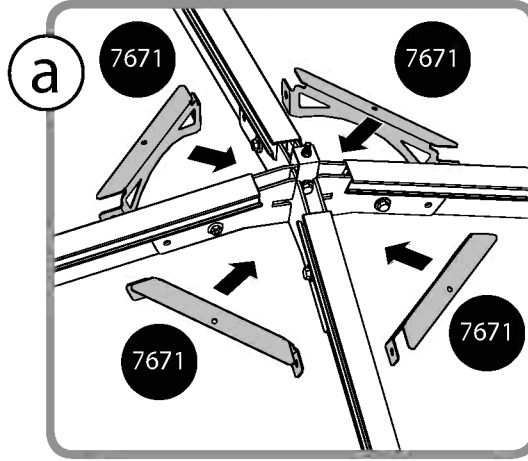
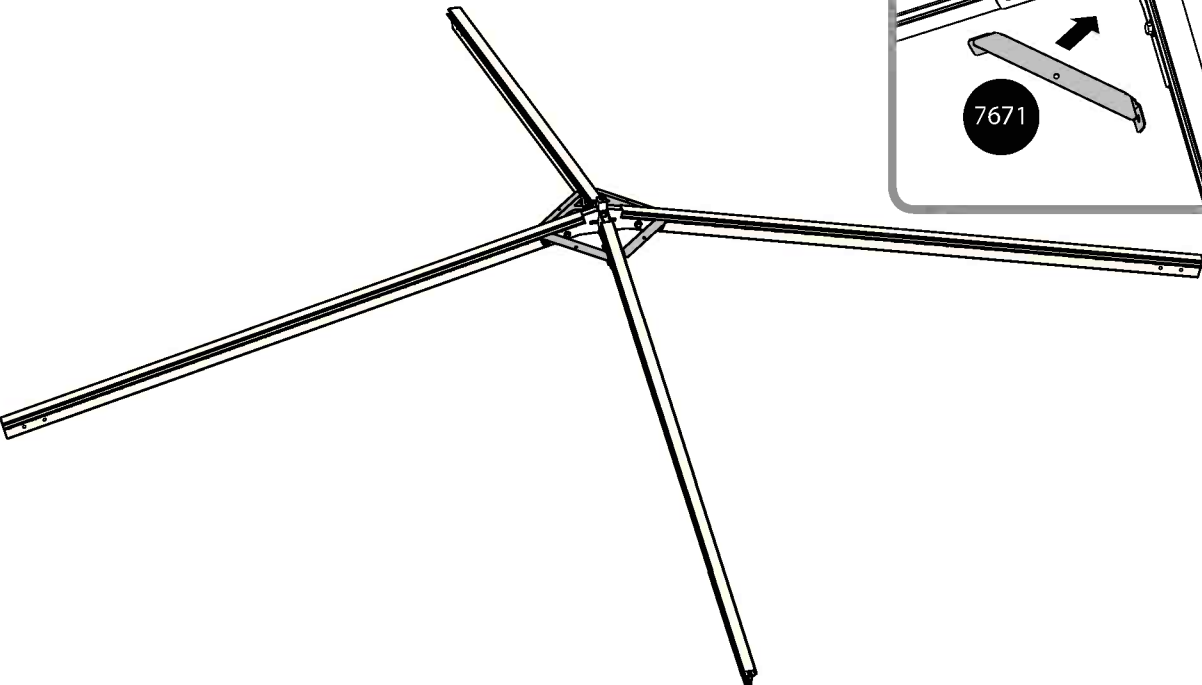

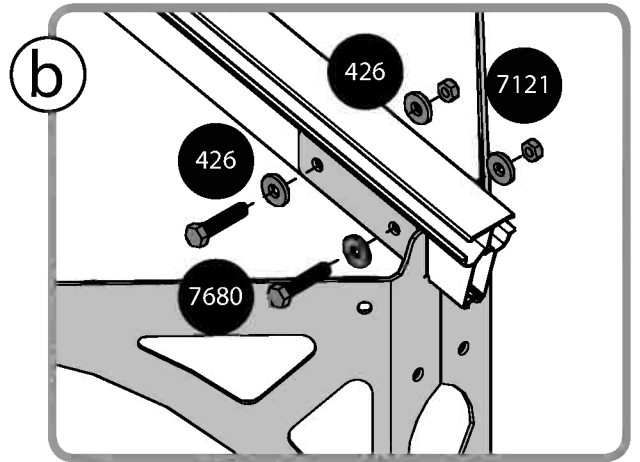
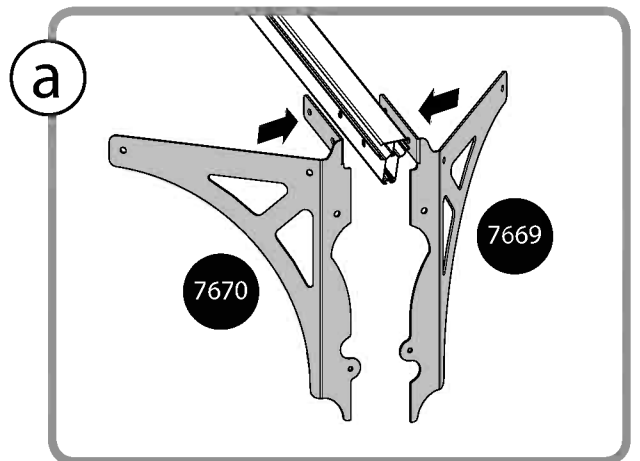
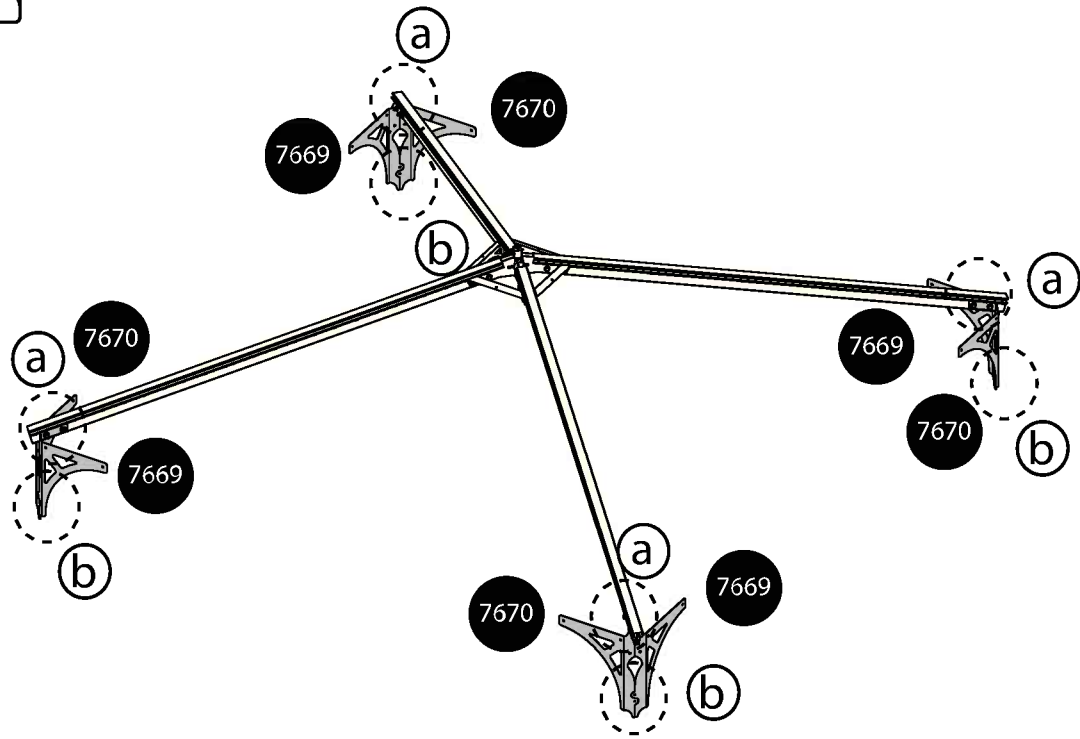
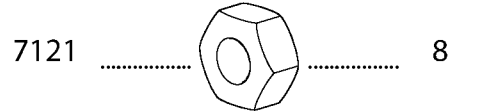
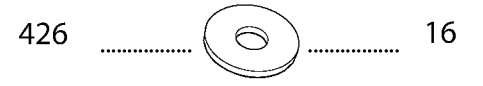
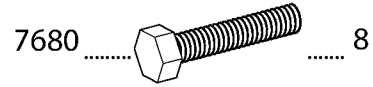
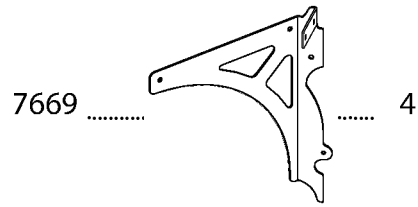
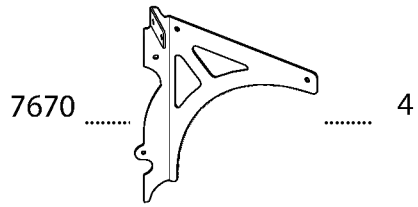

5

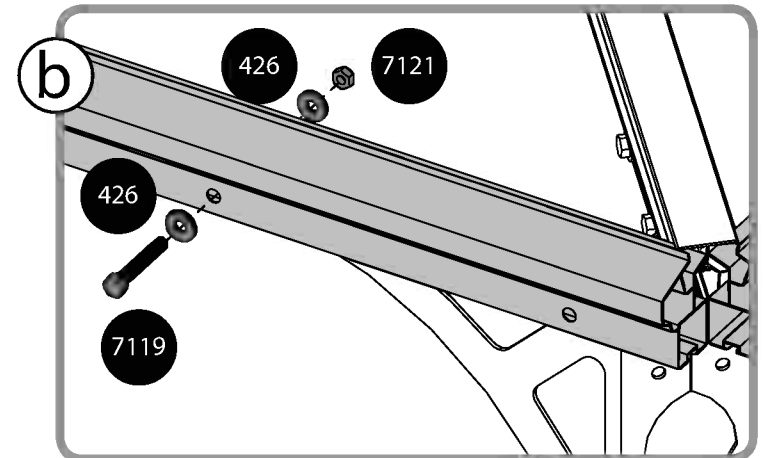
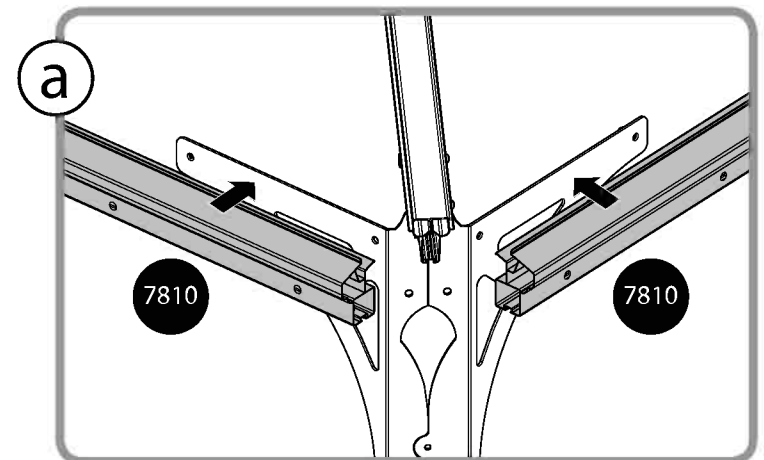
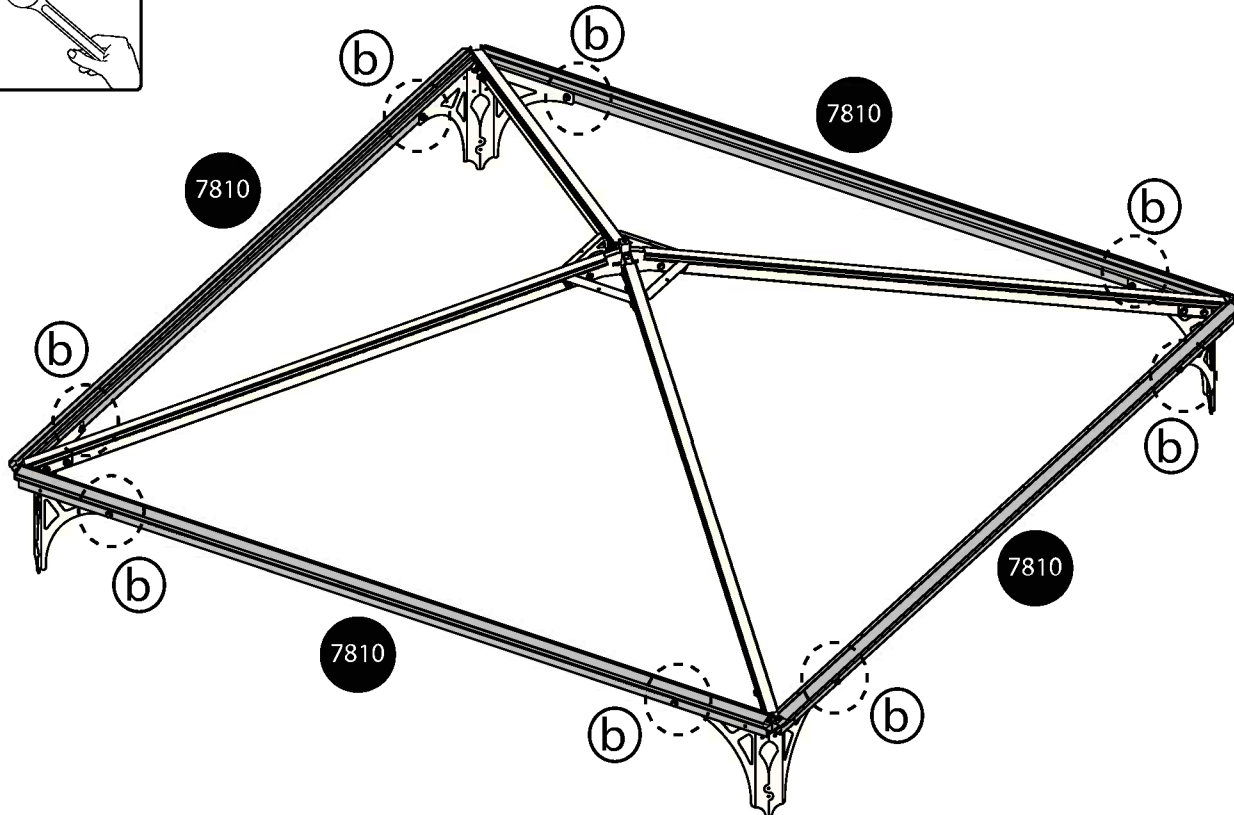
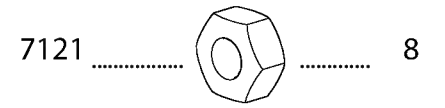
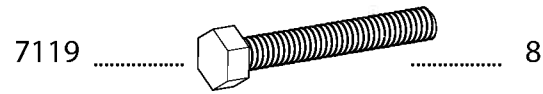
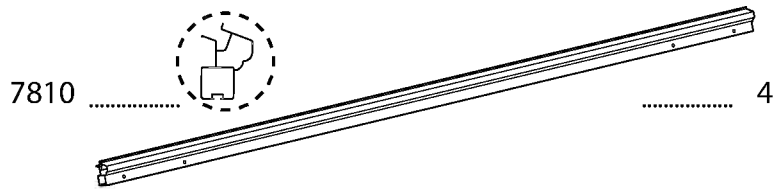

**6** **i**

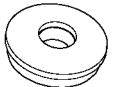

7

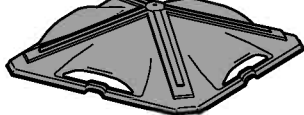
- 4024 .....  ..... 1
- 413 .....  ..... 1
- 7662 .....  ..... 1

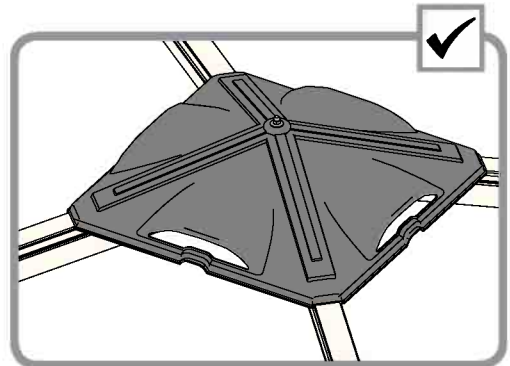
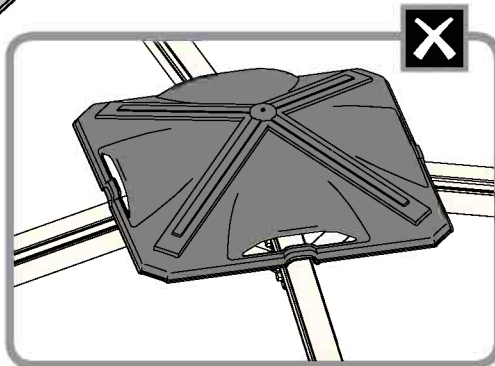
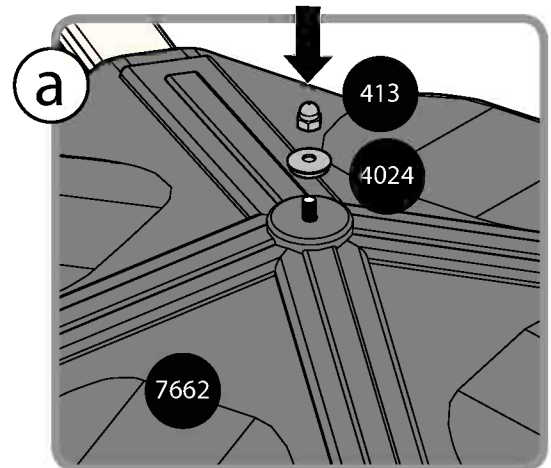
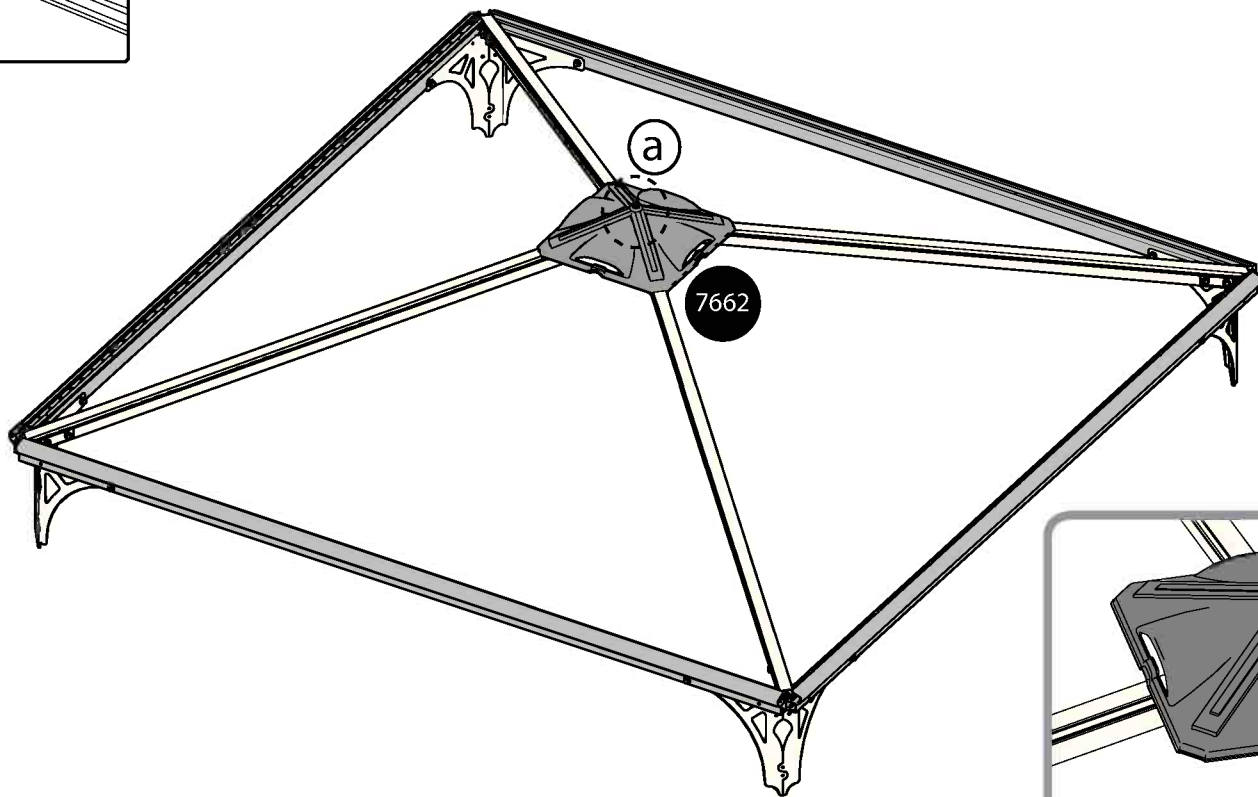
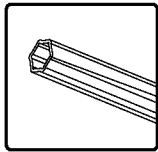







466 ..... 4

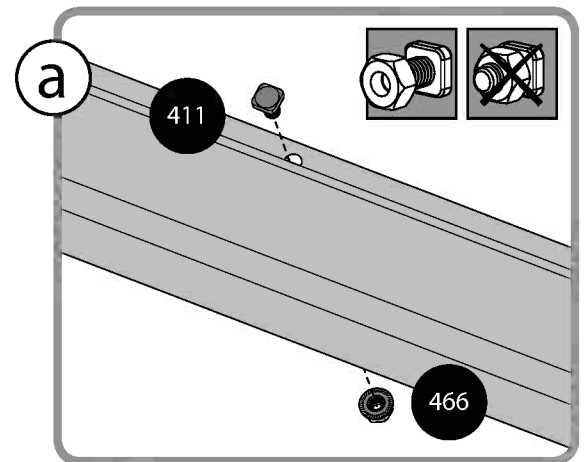
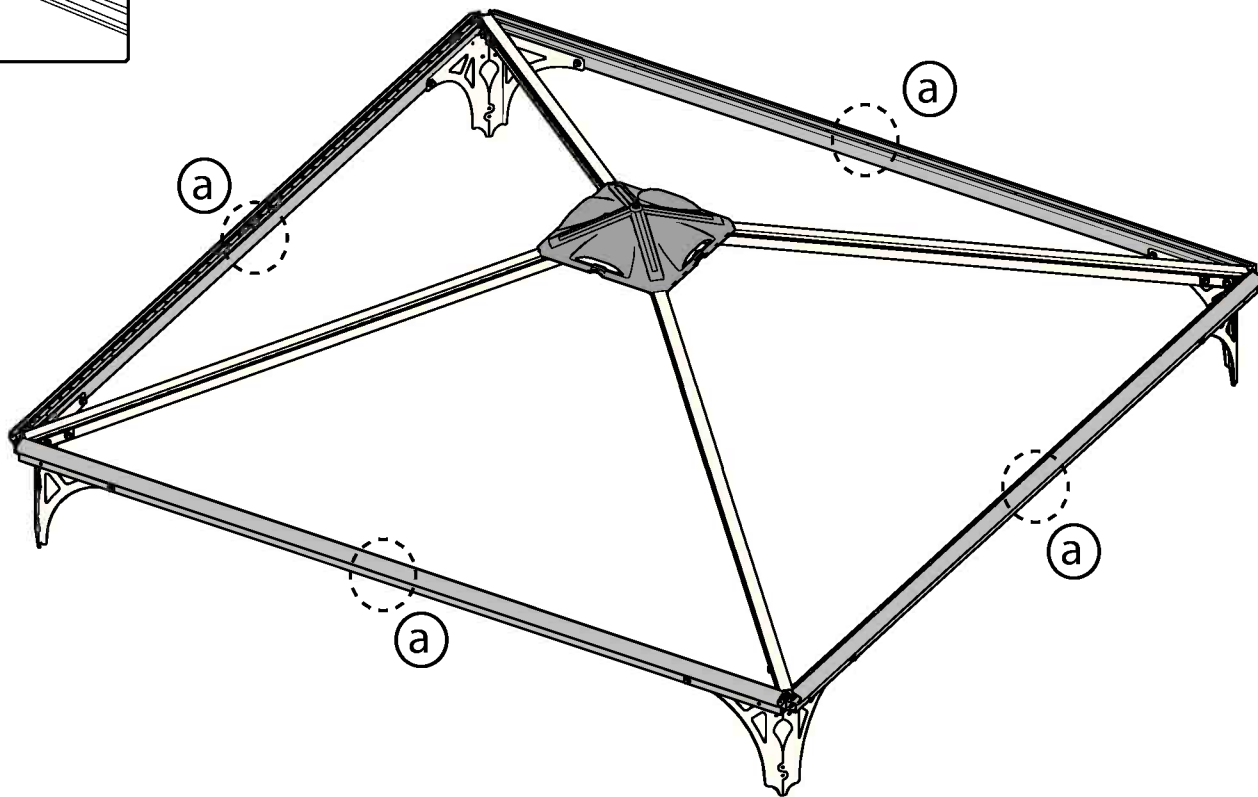
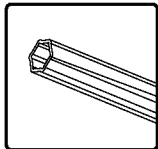
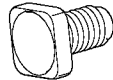

411 ..... 4

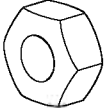
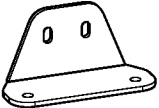
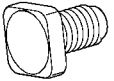
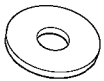

- |      |   |   |      |   |    |      |   |   |
|------|---|---|------|---|----|------|---|---|
| 7664 |  | 4 | 7121 |  | 8  | 212  |  | 8 |
| 411  |  | 8 | 426  |  | 16 | 7567 |  | 8 |

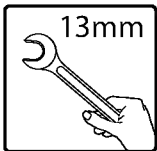

x4

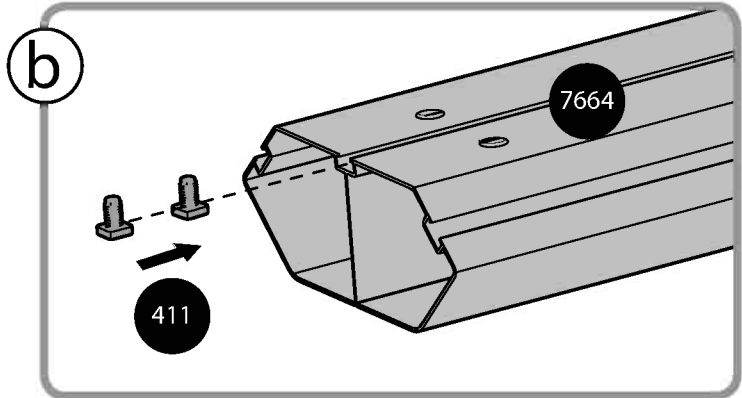
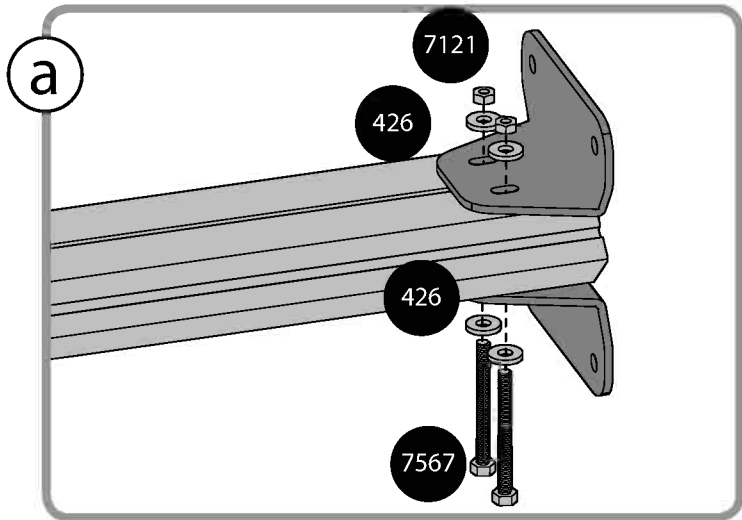
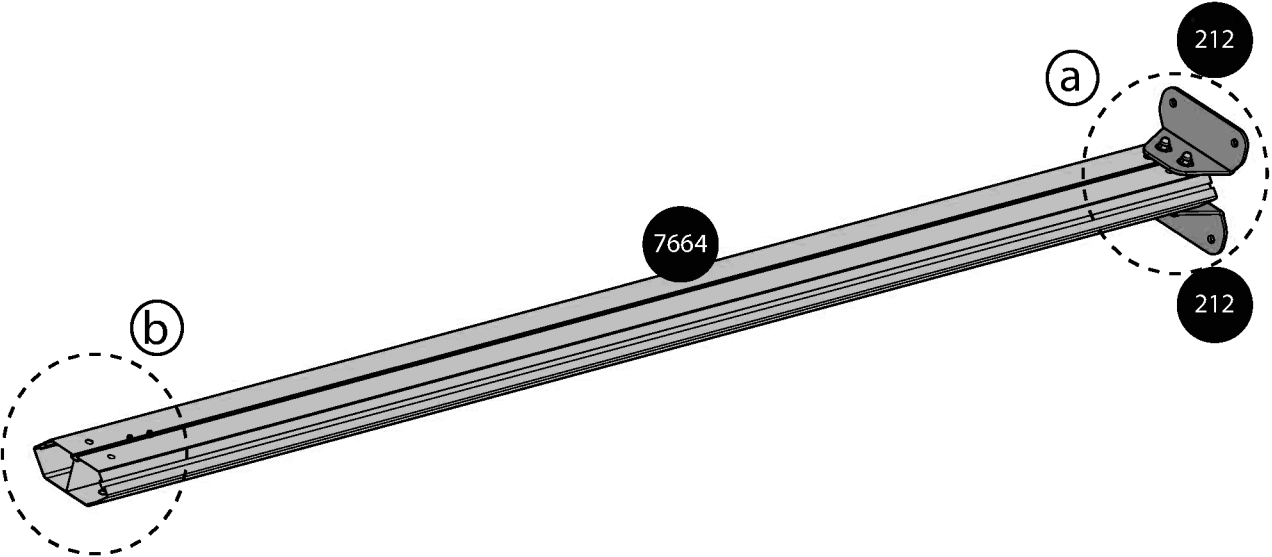

7829 .....  ..... 65

**a**

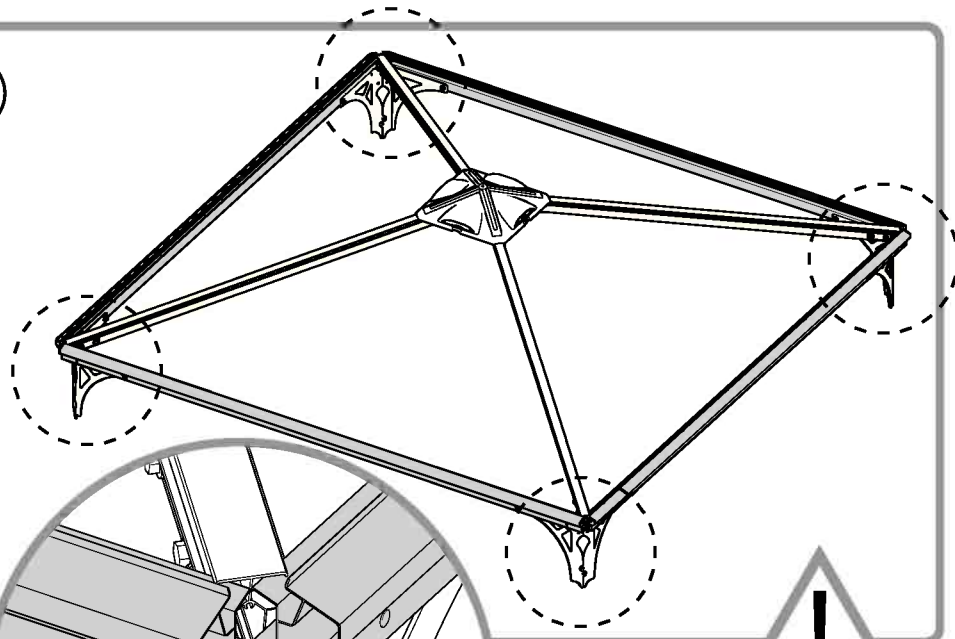

Option

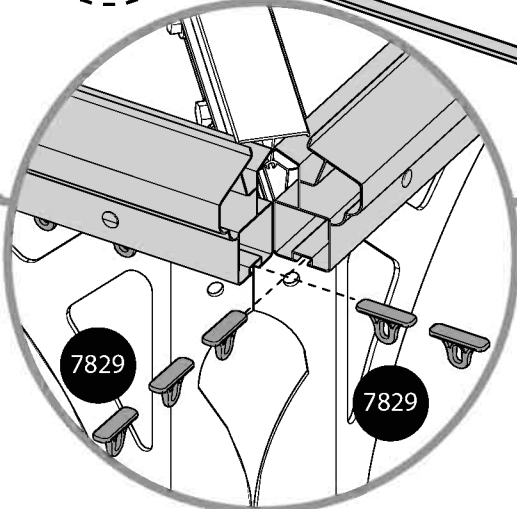

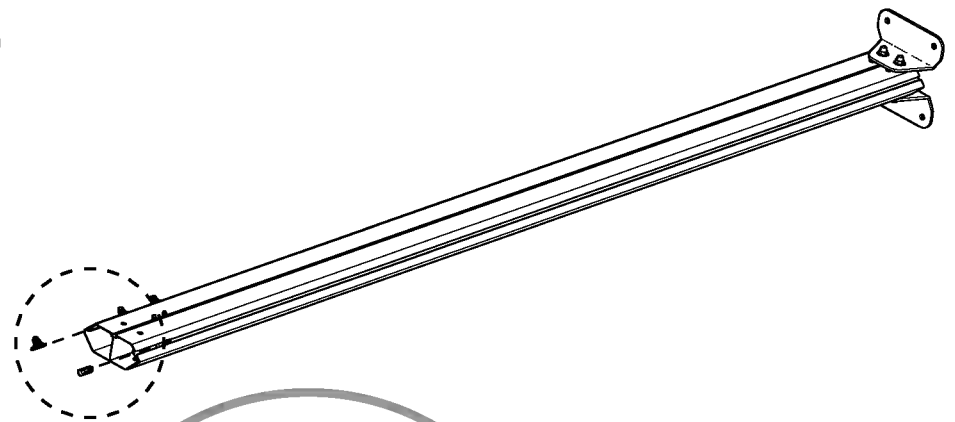

**b**



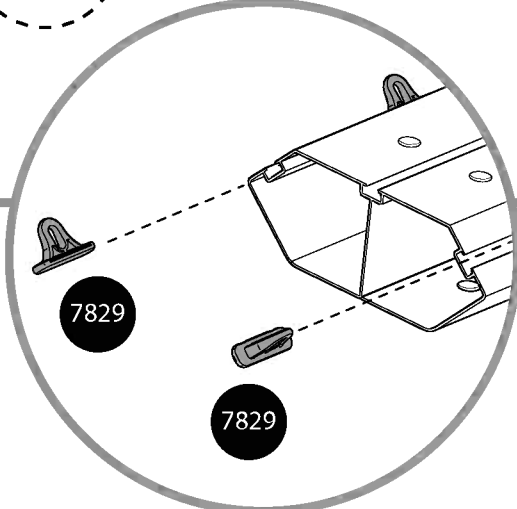

Option

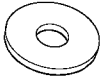

11 **i**

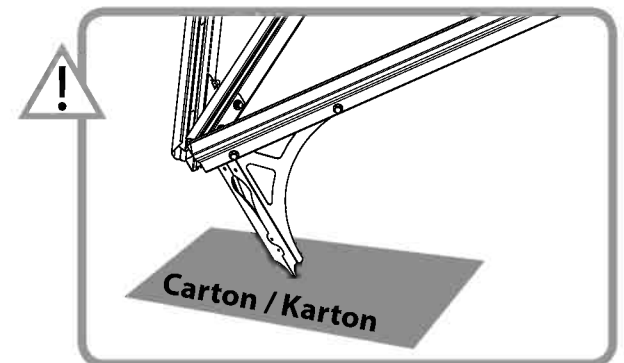
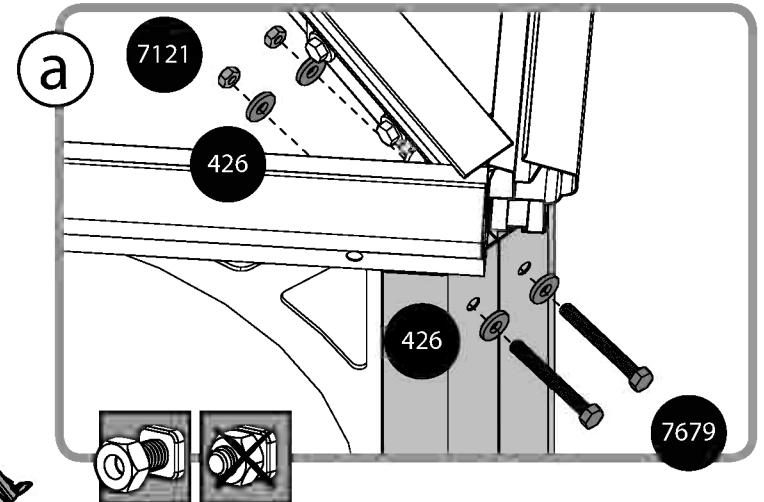
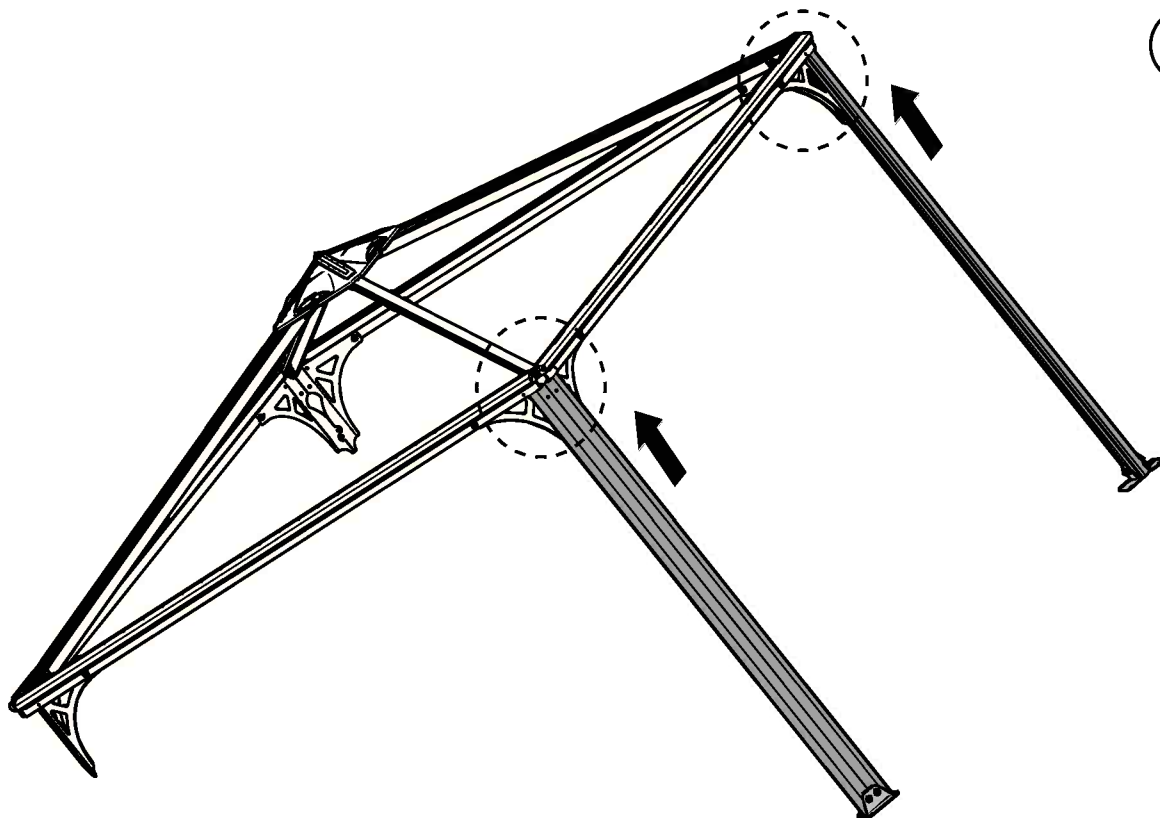
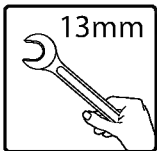
- 7679 .....  ..... 4      7121 .....  ..... 4      426 .....  ..... 8



466 .....  ..... 4

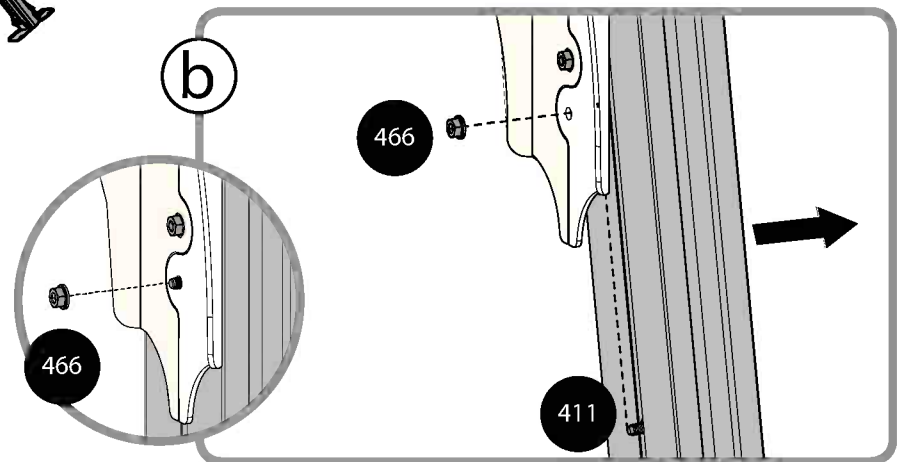
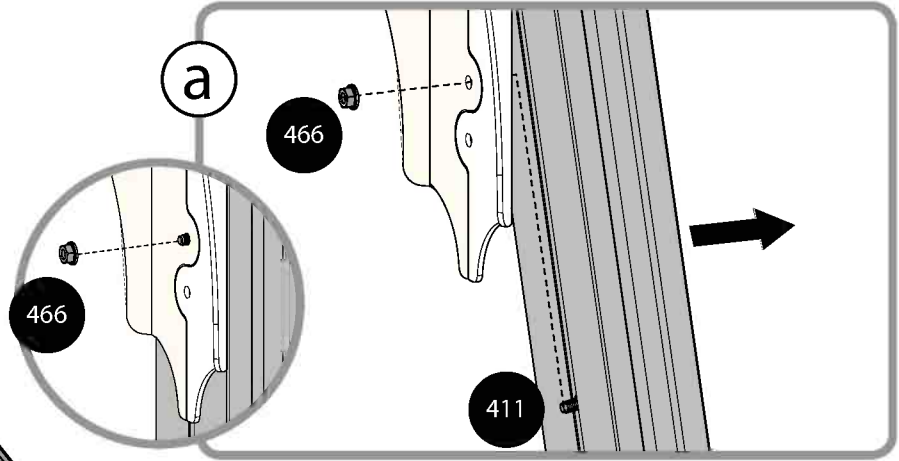
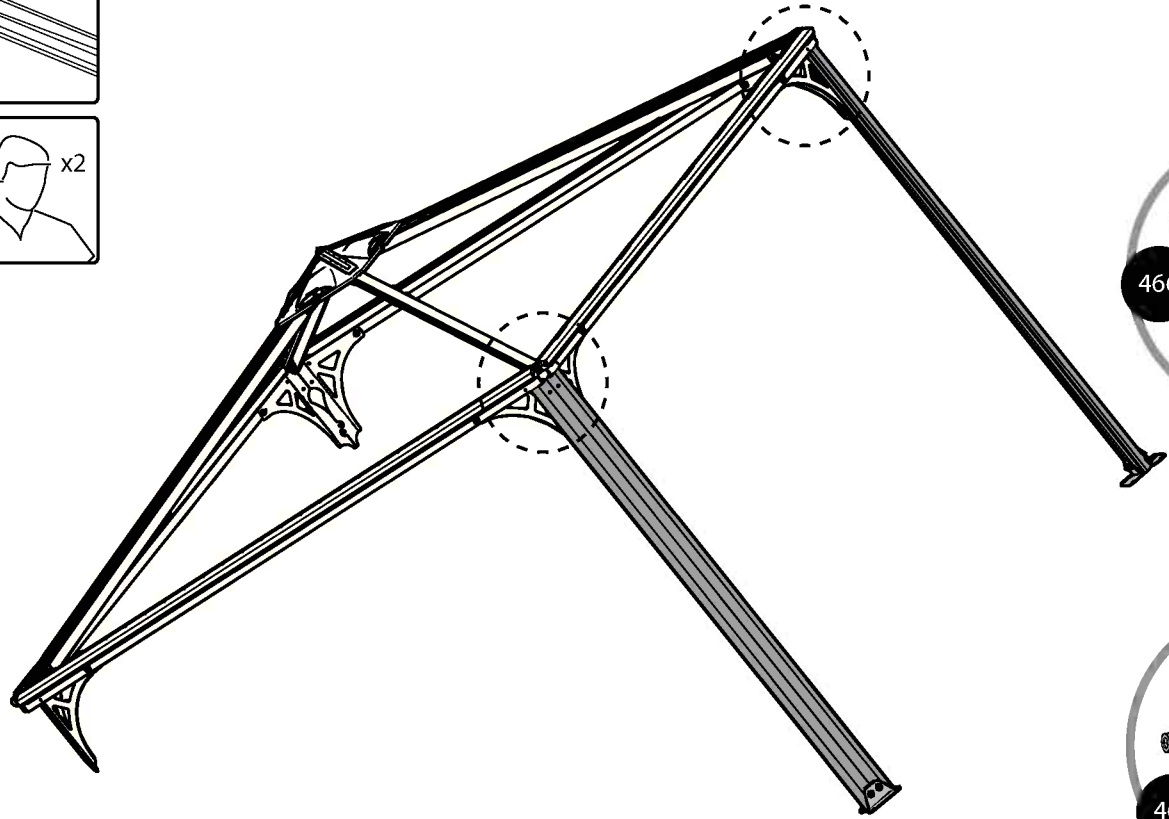
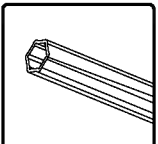

13 **i**

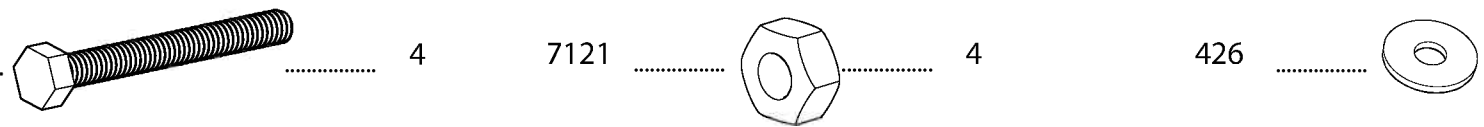
- 7679 ..... 4      7121 ..... 4      426 ..... 8
- 

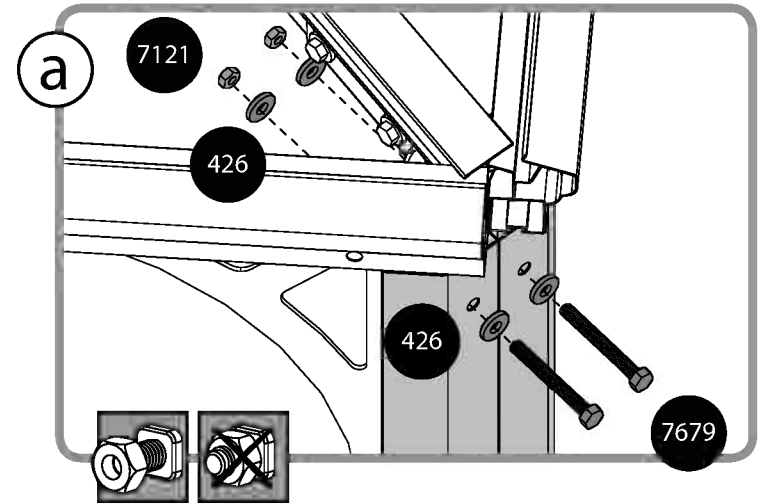
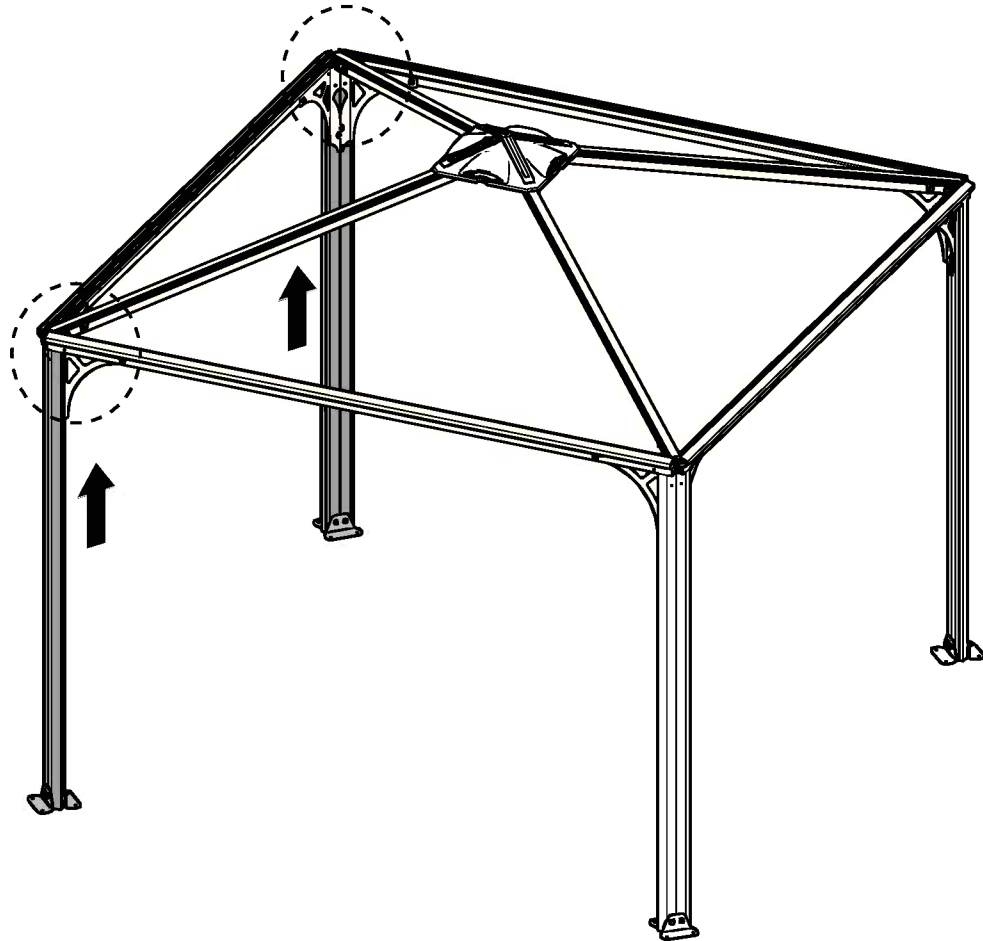
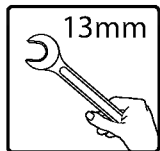

466 .....  ..... 4

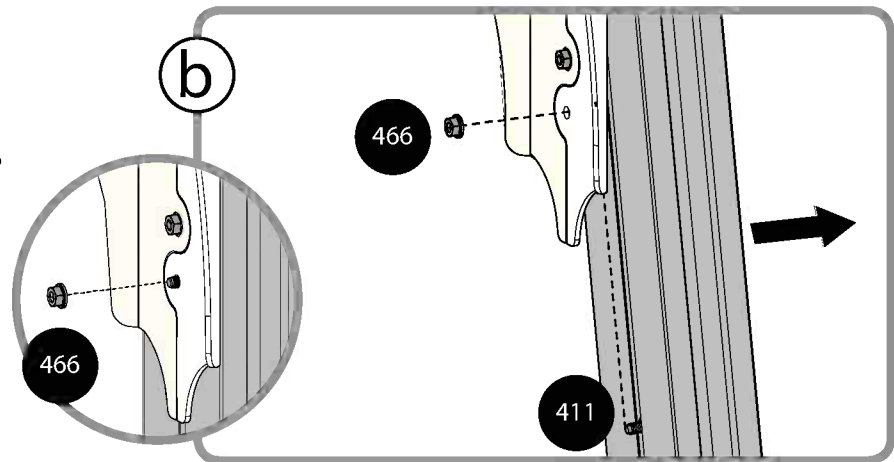
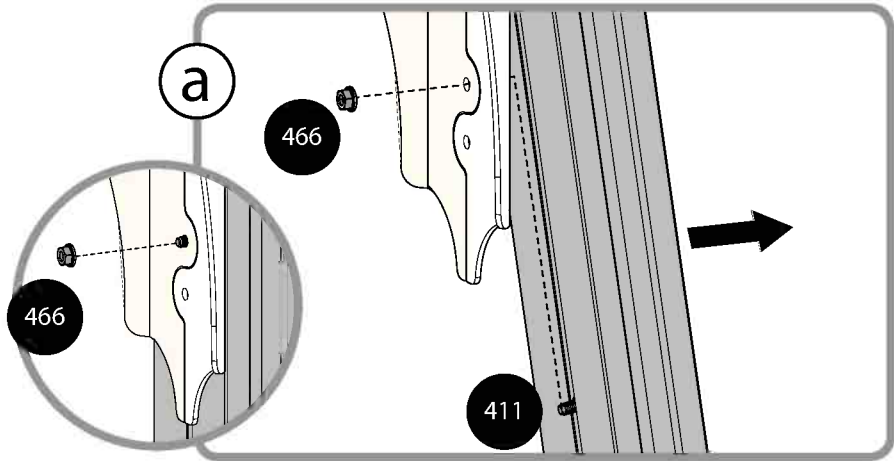
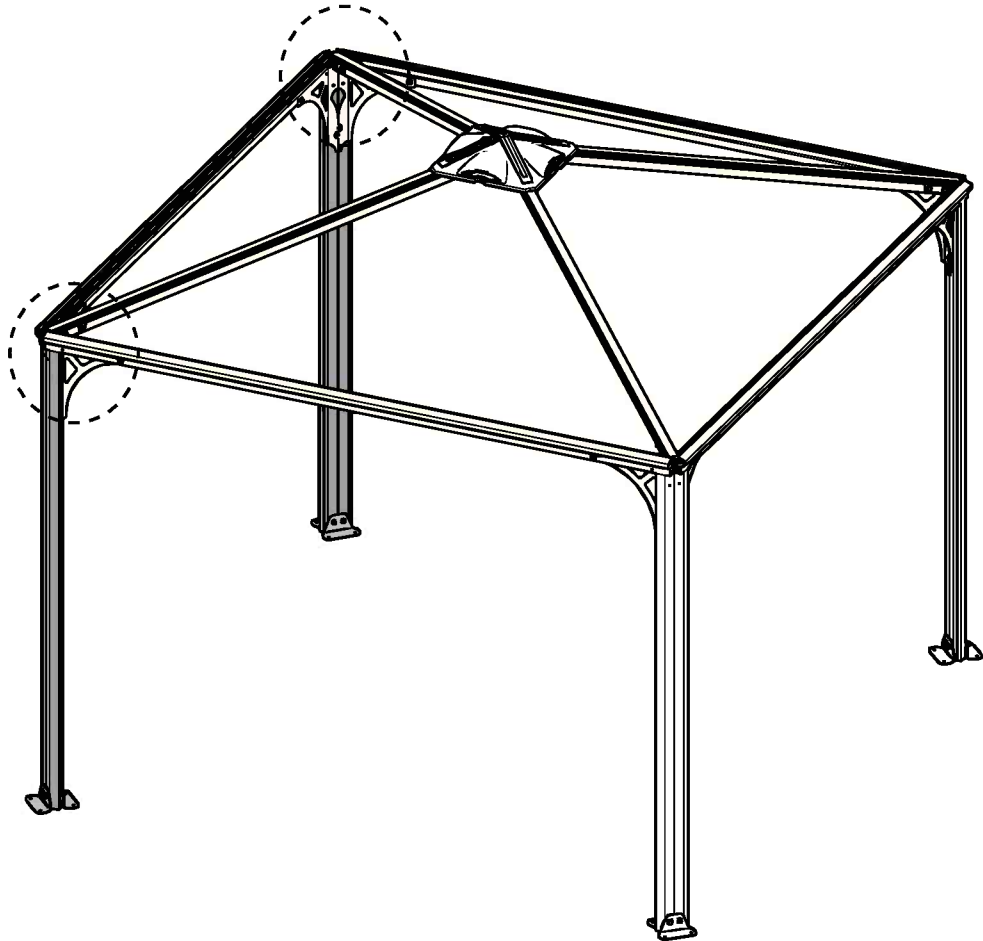
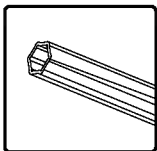

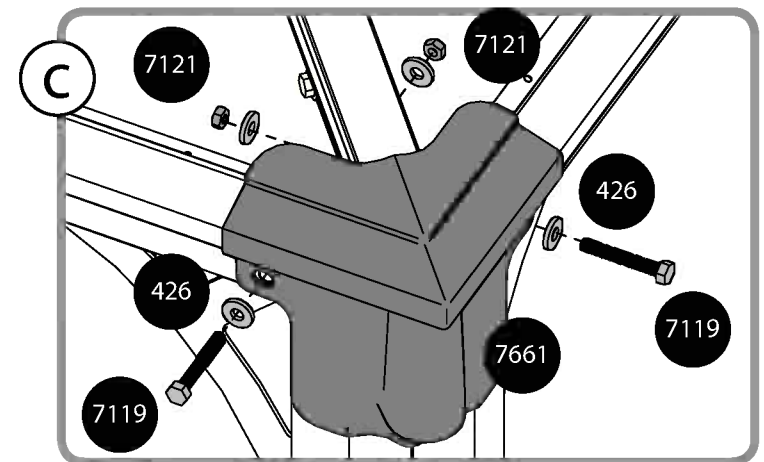
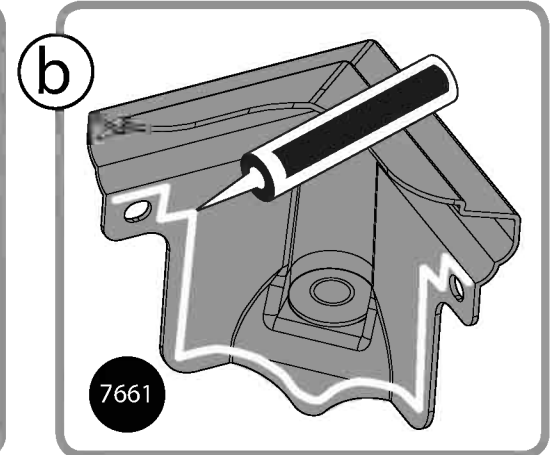
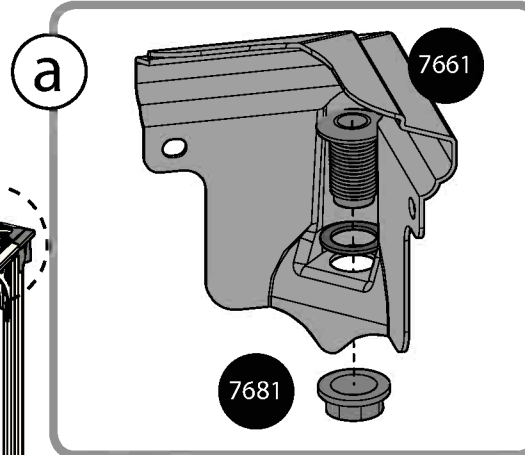
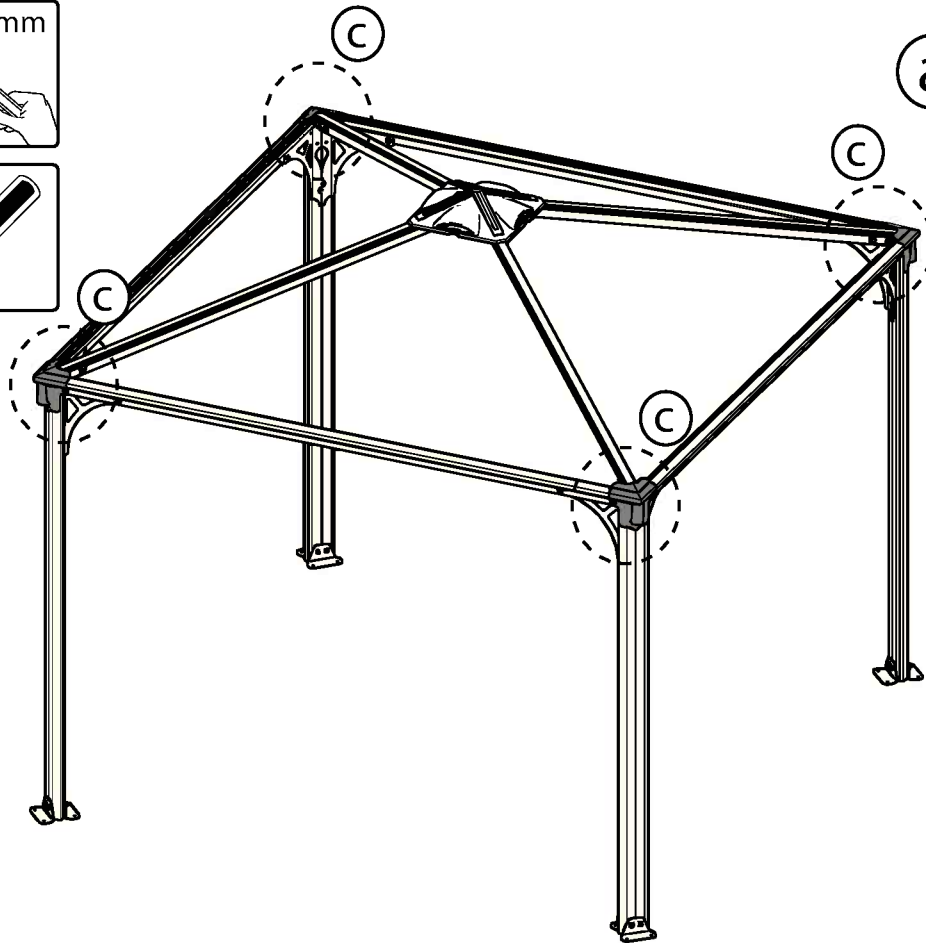
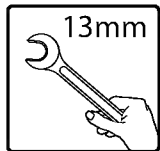
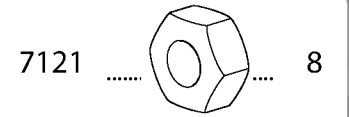
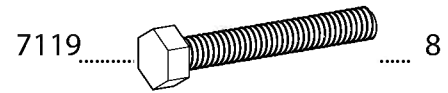
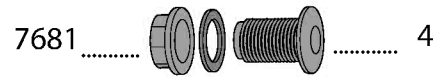
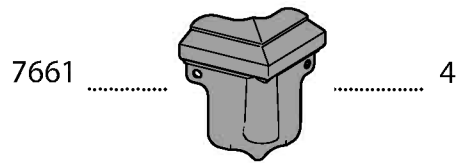



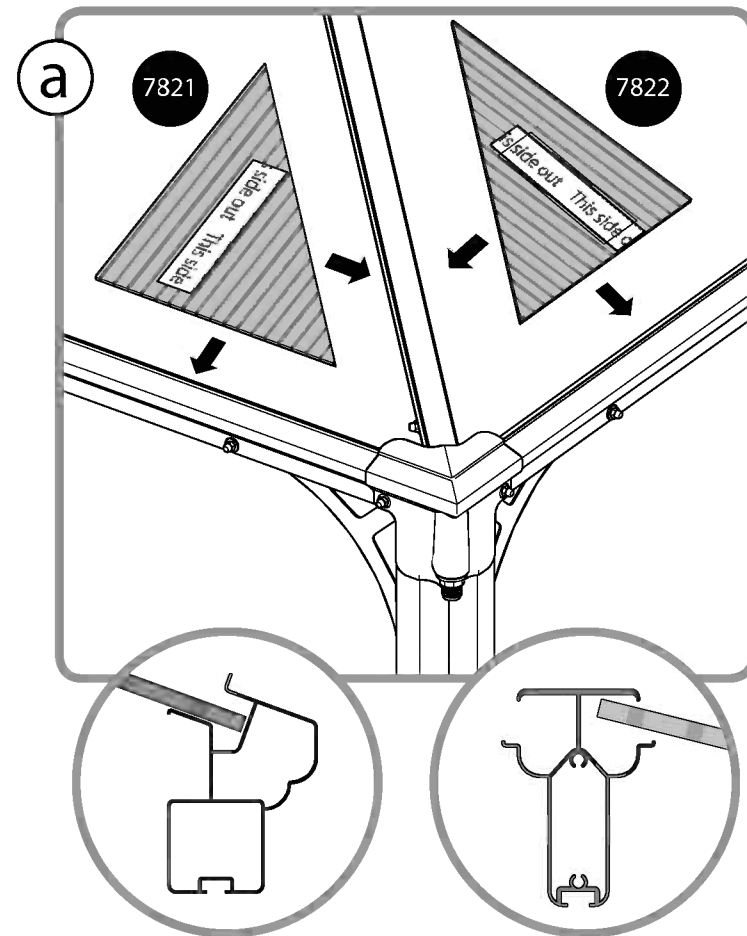
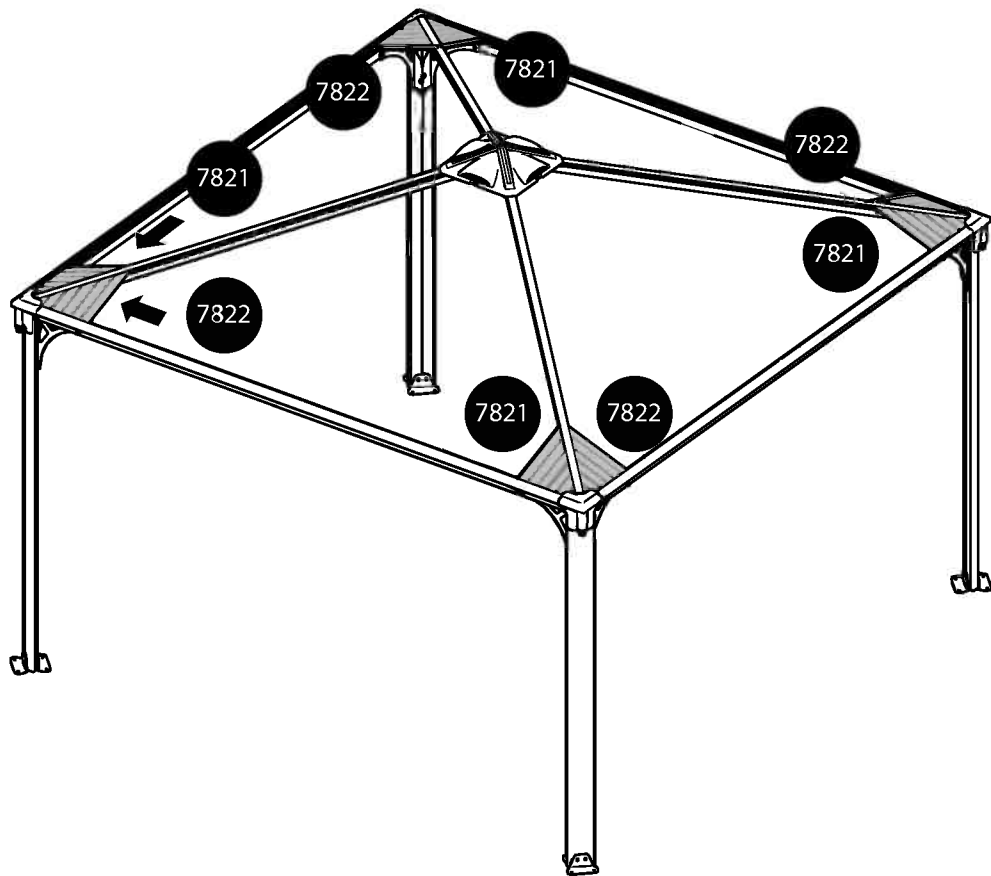

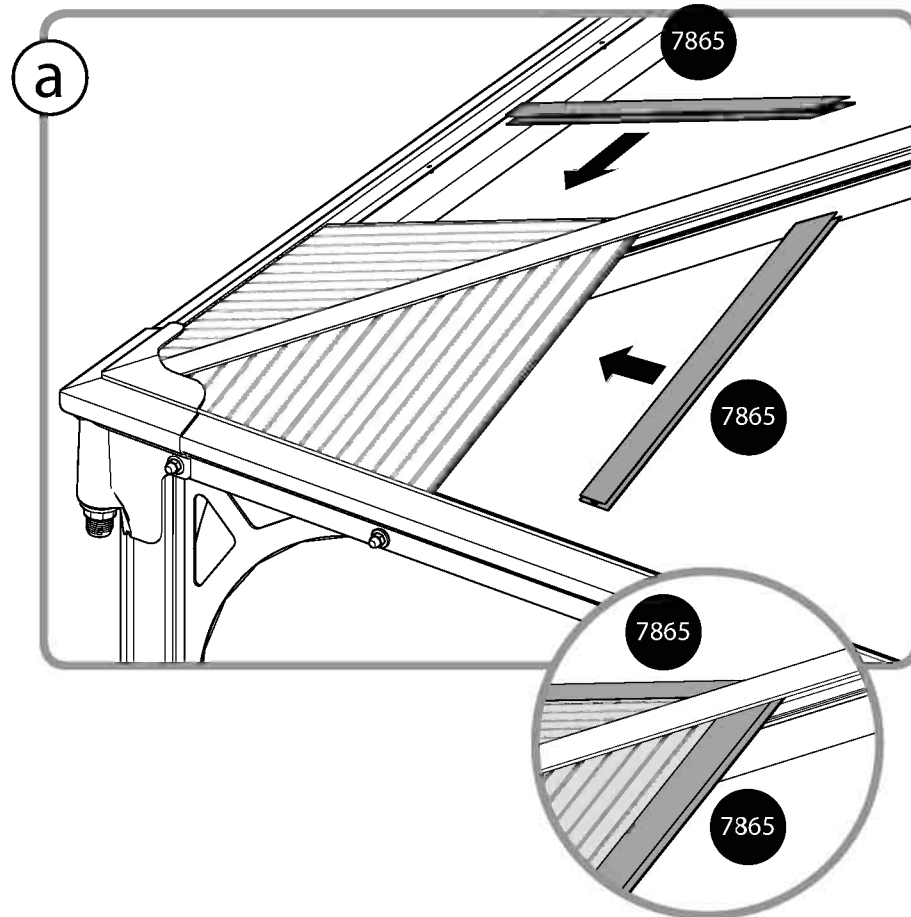
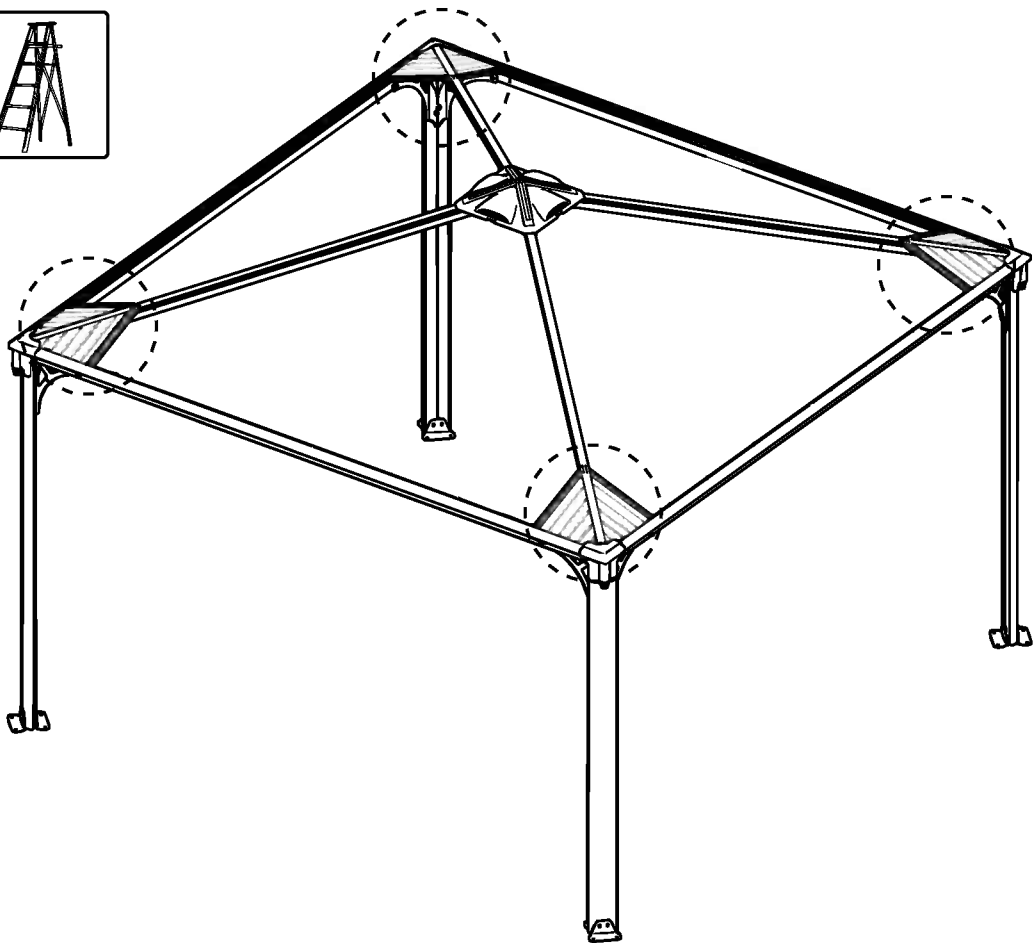
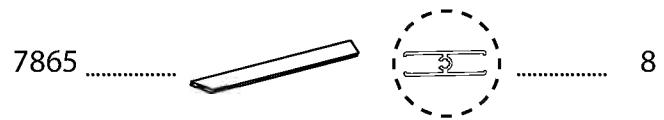

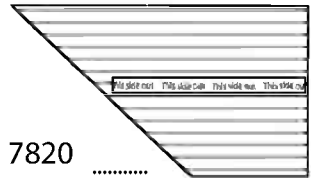

7820 ..... 4

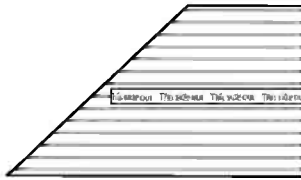

7819 ..... 4



7866 ..... 8

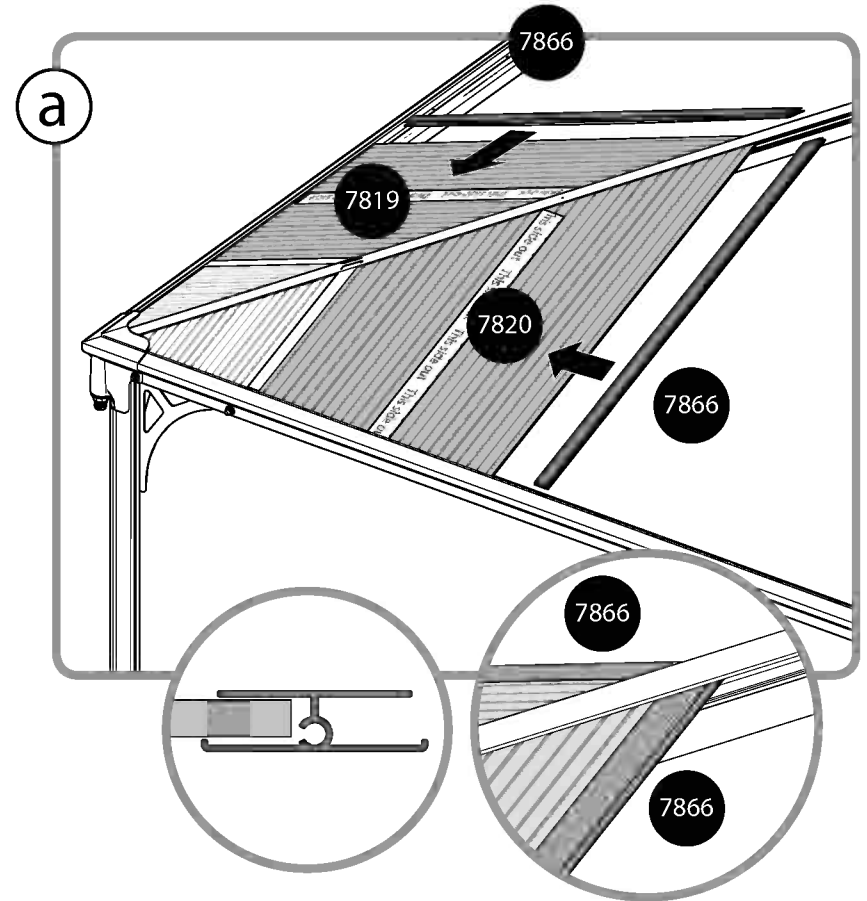
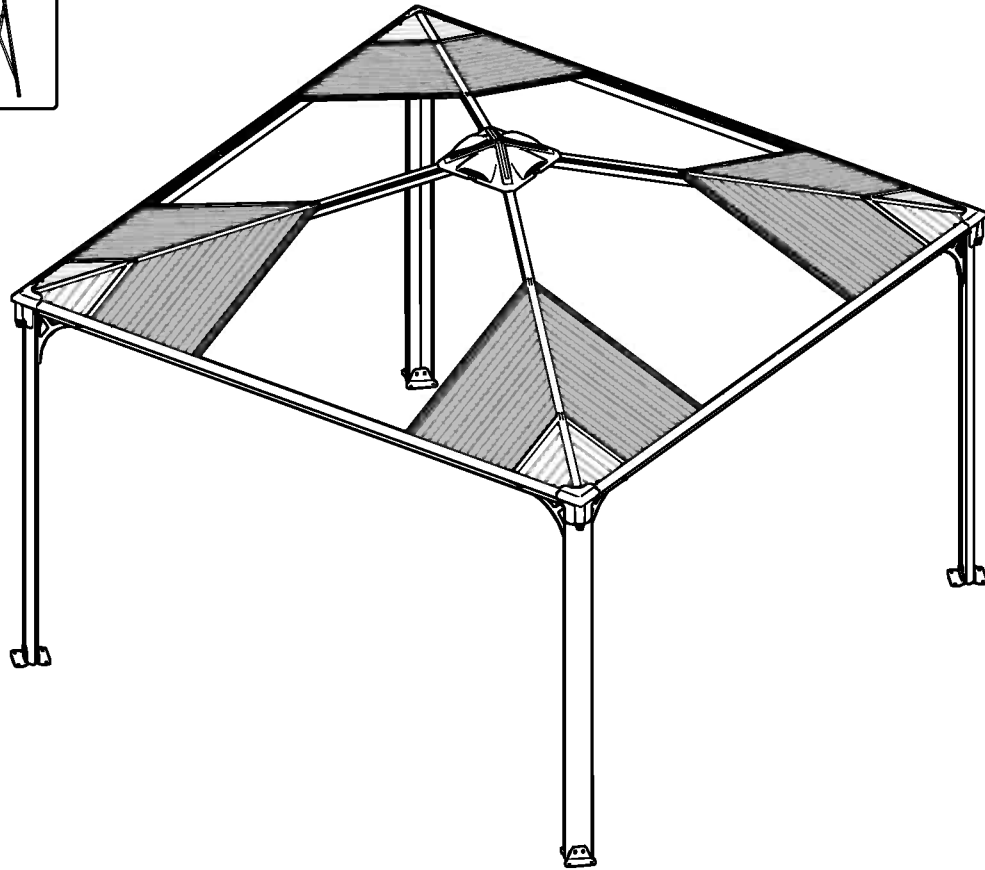

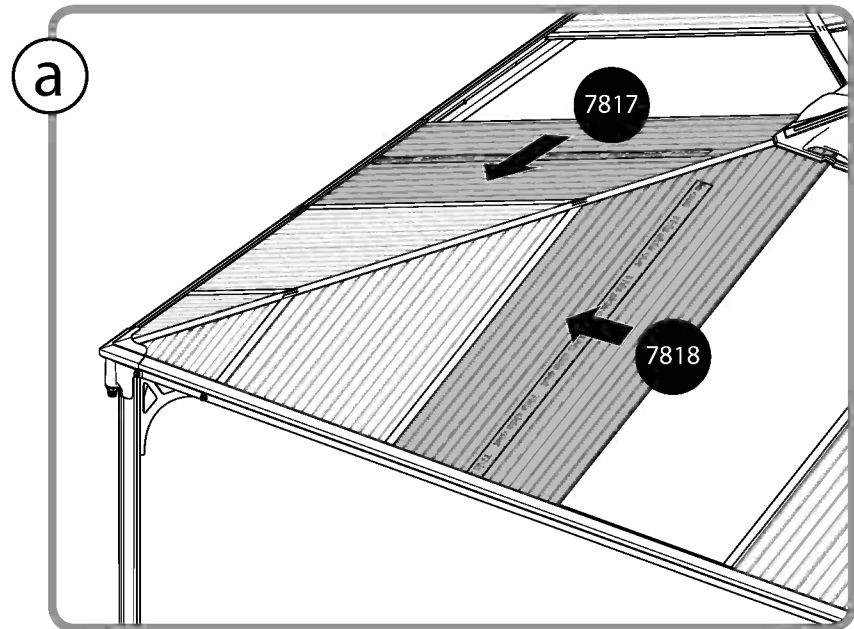
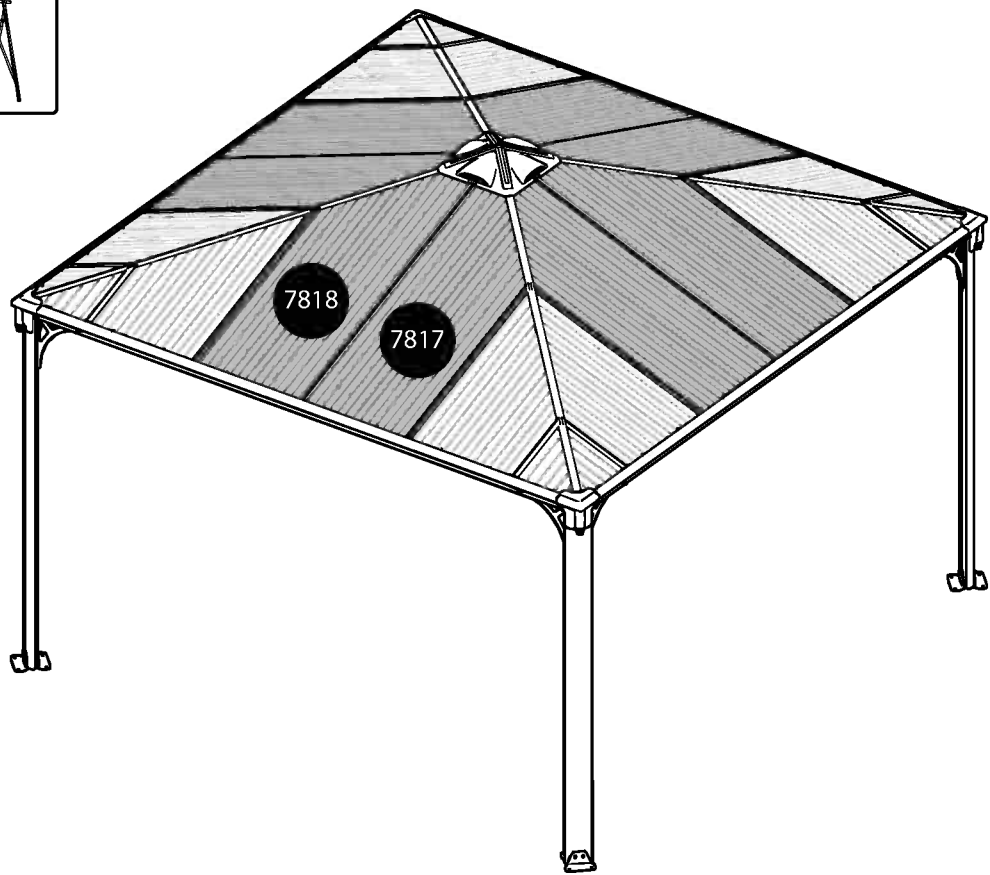
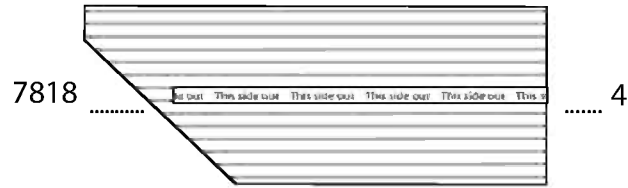
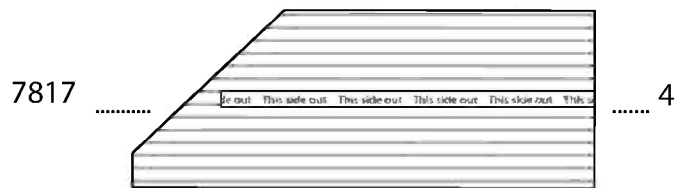



7812 .....

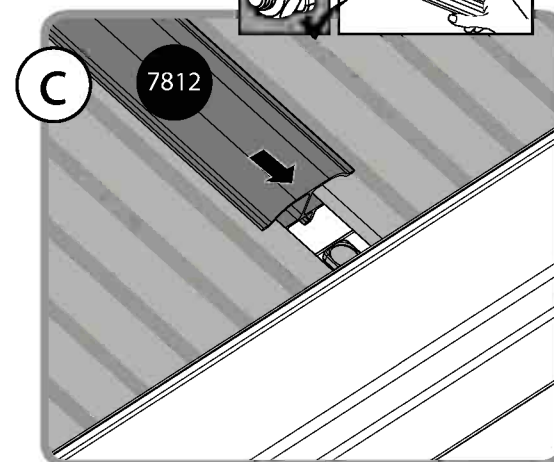
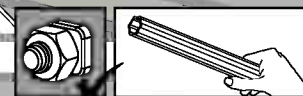
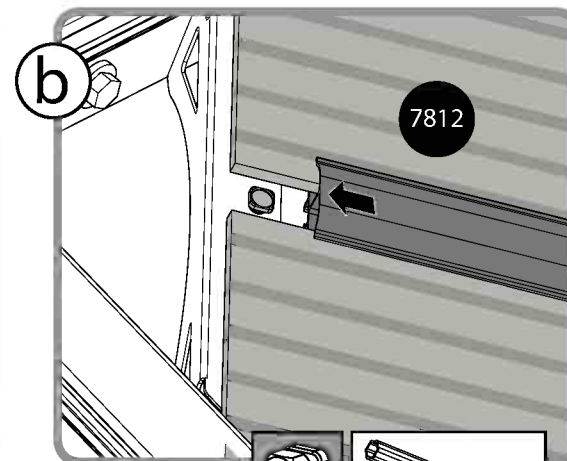
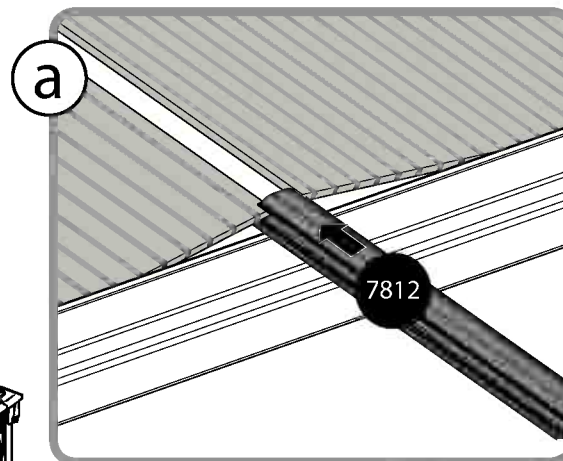
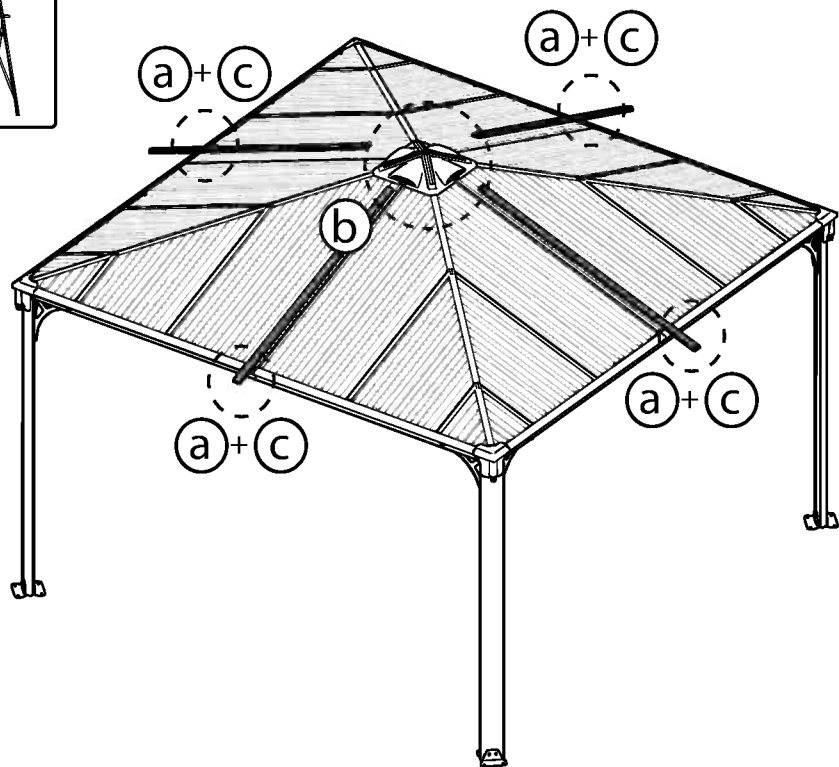
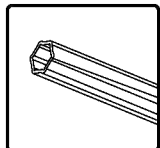

4

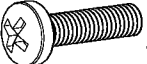

427 .....  ..... 40

421 .....  ..... 40

7024 .....  ..... 40

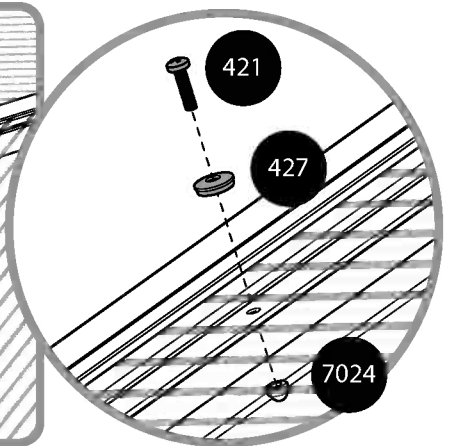
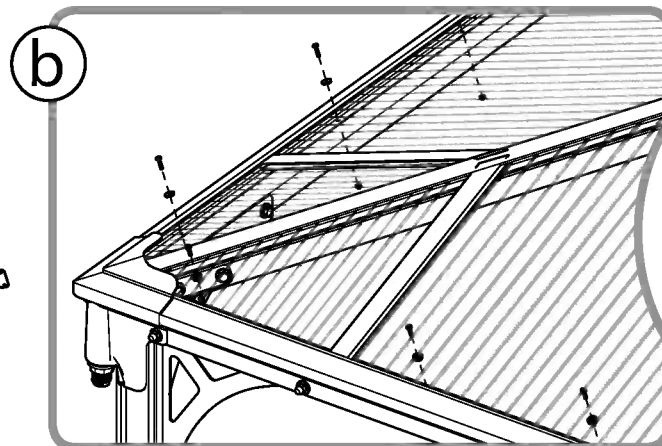
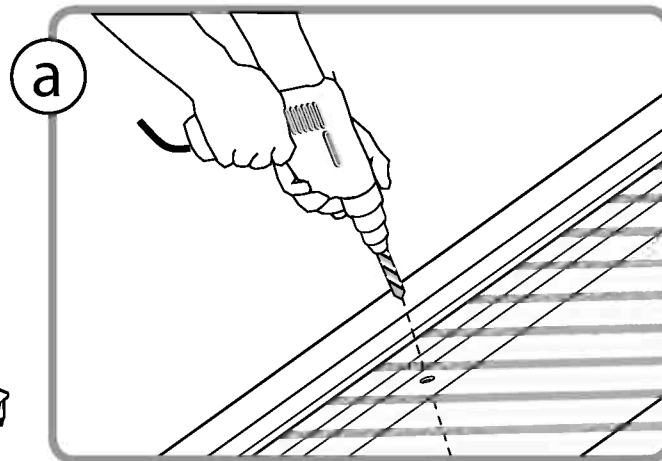
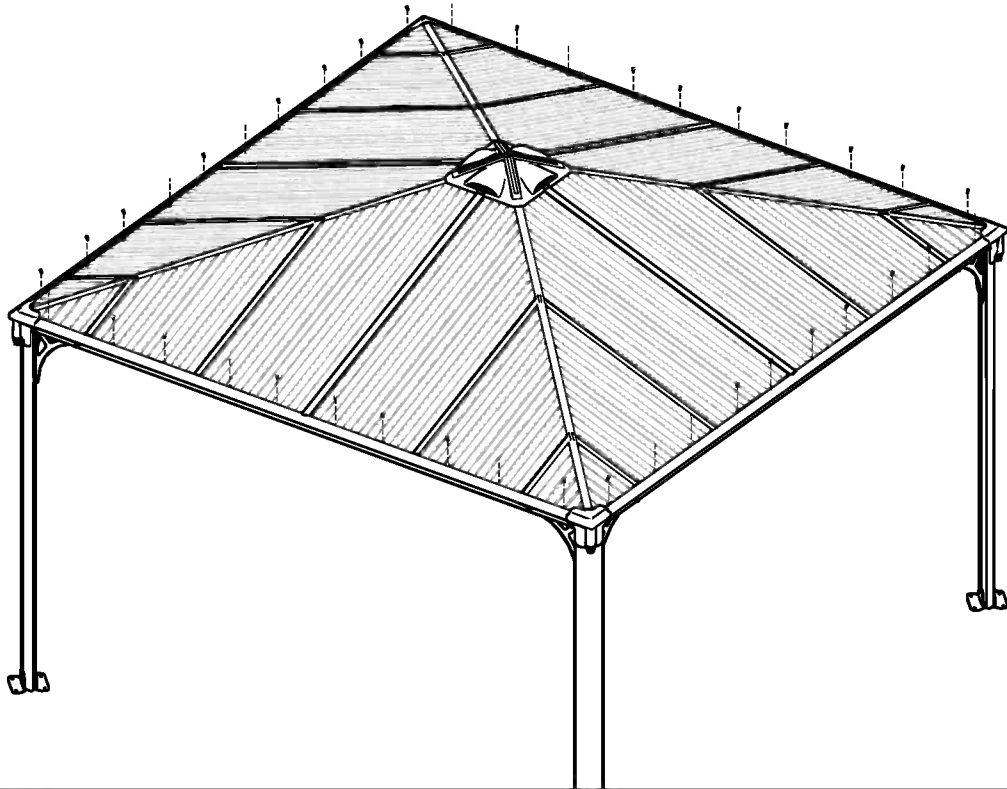
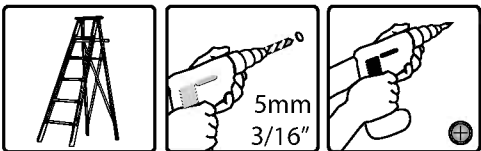

4000 ..... 16

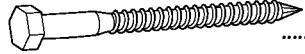

4010 ..... 16

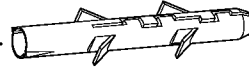

426 ..... 16

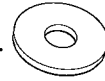

5000 ..... 32

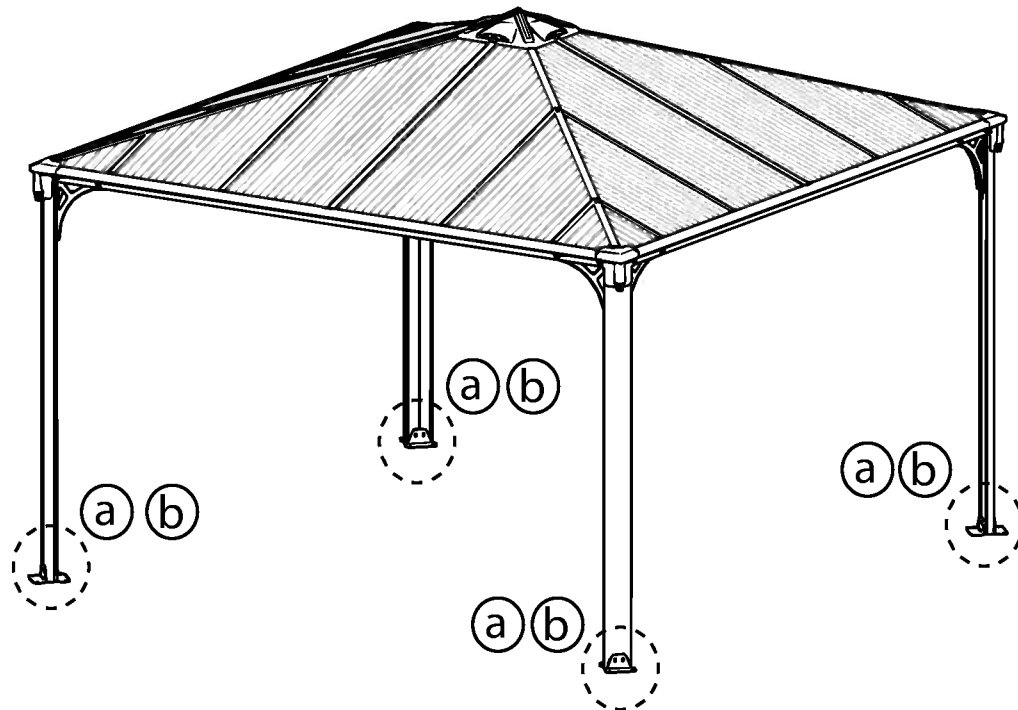
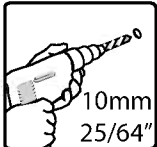
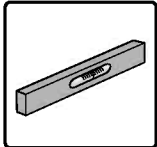
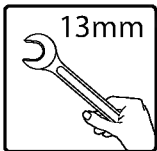

**a**

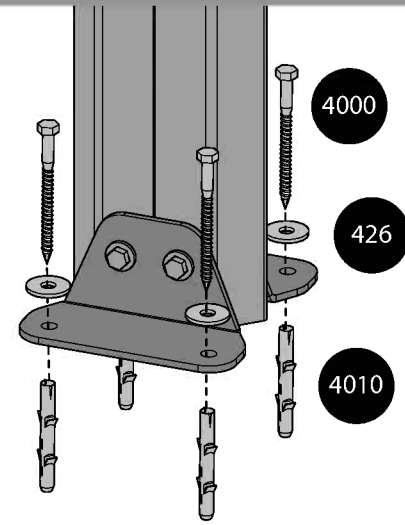

**b**

